



O-RING

O-RINGS, BACKUP RINGS AND O-RING KITS



PETSEALS INDUSTRIES LTD.
www.petseals.com

INDEX

1	Material	
2	PHYSICAL AND CHEMICAL PROPERTIES OF THE MOST IMPORTANT ELASTOMERS	
3	GLAND DIMENSIONS	
4	SURFACE IMPERFECTIONS	
5	DIMENSIONAL TOLERANCES	
6	O-RING	PAGE
	AS-568 SERIES	1-5
	JIS P SERIES	6-9
	JIS G SERIES	10-12
	GS SERIES	13
	S SERIES	14
	V SERIES	15
	JASO 1000	16
	JASO 2000	17
	JASO 3000	18
	SMS 1586	19
	ISO 6149 SERIES	20
	ISO.....	21
	METRIC SERIES (1/SS~4、7mm)	22-33
	4F SERIES	34
	POLYURETHANE O-RING	35-36
7	SQUARE RING-AS-568 SERIES	37-39
8	X-RING — AS-568 SERIES	40-44
9	HEAD SEAL HI	45-47
10	ED SEAL—DIN 3869	48
11	WD CAPTIVE SEAL	49
12	BACKUP RING	
	AS-568(80) SERIES(NBR).....	47-51
	AS-568 SERIES(HY)	55-57
	BACKUP RING P SERIES(HY+PTFE).....	58-62
	BACKUP RING G SERIES(HY+PTFE).....	62-66
	4F AS SERIES(PTFE)	67-71
	ROD SEAL BACKUP RING.....	72
	POLYURETHANE P,G SERIES(PU)	73
	4F (HY)	74-76
12	O-RING KIT	77-89
13	CONTROL VALVE O RING KITS	90

Material

MATERIAL	TENSILE STRENGTH (KG/CM²)	ELONGATION(%)	TEMPERATURE RANGE(°C)	HRSX°C	%MAX
NITRILE 70 (NBR 70)	160	300	-30°C ~100°C	70H x 100°C	20
NITRILE 90 (NBR90)	175	150	-25°C ~100°C	70H x 100°C	25
HNBR 70	200	300	-40°C~120°C	70H x 100°C	25
FLUORO-CARBON 70 (FKM 70)	125	200	-20°C~200°C	70H x 200°C	18
POLYA-CRYLATE 70 (AR 70)	120	170	-20°C~150°C	70H x 150°C	30
SILICONE 70 (SE 70)	65	200	-50°C~200°C	70H x 225°C	12
ETHYLENE PROPYLE 70 (EPDM 70)	140	250	-40°C~120°C	70H x 100°C	25

Physical and chemical properties of the most important elastomers

Compound	N	V	S	AS
Basic Polymer	Nitrile	Fluorocarbon	Silicone	Aflas
ASTM-Code	NBR	FKM	VMQ	-
Shore Hardness(Shore A)	60-95	60-90	30-80	70
Non inflammable hydraulic fluids	-	x to xxxx	xx	xxxx
Hydraulic oils and lubricating oils	xxxx	xxxx	xx	xxxx
Fuel oils	xx	xxxx	x	xxxx
Animal and vegetable oils and fats	xxxx	xxxx	xxx	xxxx
Brake Fluid	-	-	xx	xxxx
Silicone and Grease	xx	xxxx	xx	xxxx
Gasoline	xxx	xxxx	x	xxxx
Premium grade gasoline	xx	xxxx	-	xxxx
Kerosene	xxx	xxxx	x	xxxx
Aromatic Hydrocarbon	x	xxxx	-	xxxx
Aliphatic Hydrocarbon	xxx	xxxx	x	xxxx
Water (under + 80°C)	xxx	xxxx	xxxx	xxxx
Water (over + 80°C)	x	xx	xxx	xxxx
Alcohols	xx	x to xxxx	xxxx	xxxx
Ketones	-	-	xx	xxx
Acid(concentrated)	-	xxx	x	xxx
Acid(diluted)	x	xxxx	xx	xxxx
Lye	x	xx	xx	xxx
Chlorinated Hydrocarbon	x	xxx	-	xxx
Ozone and Sunlight	x	xxxx	xxxx	xxx

key : xxxx very good
 xxx good
 xx satisfactory
 x poor
 - unsatisfactory

Gland dimensions

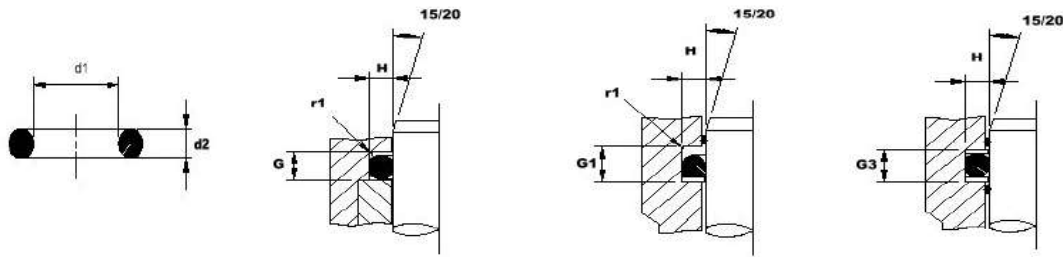

C/S d2 (mm)	Pressure			No Back-Up 100 Bar max		One Back-Up >100 Bar		Two Back-Up 100 Bar alternatin		Radius r1 (mm)
	stat	Dynam.	Pneum	H (mm)	G (mm)	H (mm)	G1 (mm)	H (mm)	G2 (mm)	
1.00	x			0.70	1.40	-	-	-	-	0.20
1.50	x			1.14	2.40	-	-	-	-	0.30
1.60	x			1.21	2.40	-	-	-	-	0.30
1.78	x	x		1.49	2.50	1.50	4.16	1.50	6.16	0.40
1.78			x	1.58	2.50	-	-	-	-	0.40
1.90	x			1.40	2.60	-	-	-	-	0.40
1.90		x		1.55	2.60	1.55	4.00	1.55	5.40	0.40
2.00	x	x		1.68	2.80	1.70	4.20	1.70	5.60	0.40
2.40		x		1.80	3.30	2.05	4.70	2.05	6.10	0.50
2.40			x	2.16	3.30	-	-	-	-	0.50
2.40	x			1.90	3.20	-	-	-	-	0.50
2.50		x		2.12	3.50	2.15	4.90	2.15	6.30	0.50
2.50	x		x	2.28	3.50	-	-	-	-	0.50
2.62	x	x		2.25	3.25	2.28	4.65	2.28	6.50	0.60
2.62			x	2.36	3.25	-	-	-	-	0.60
2.70	x	x		2.30	3.60	2.30	5.00	2.30	6.40	0.60
2.95	x	x		2.20	3.90	2.50	5.30	2.50	5.30	0.60
3.00		x		2.58	4.10	2.60	5.50	2.60	6.90	0.60
3.00			x	2.72	4.10	-	-	-	-	0.60
3.00	x			2.45	3.80	-	-	-	-	0.60
3.10	x	x		2.50	4.10	2.70	5.50	2.70	6.90	0.60
3.50	x	x		2.65	4.60	3.05	6.00	3.05	7.40	0.60
3.53	x	x		2.70	4.80	3.10	6.20	3.10	7.60	0.80
3.53			x	3.21	4.40	-	-	-	-	0.80
3.60	x	x		2.28	4.80	3.15	6.20	3.15	7.60	0.80
4.00	x	x		3.46	5.40	3.51	6.80	3.51	8.20	0.80
4.50	x	x		3.50	5.80	4.00	7.50	4.00	9.20	0.80
5.00	x	x		4.45	6.70	4.46	8.50	4.46	10.30	0.80
5.00			x	4.65	6.70	-	-	-	-	0.80
5.30	x	x		4.72	6.45	4.75	7.66	4.75	10.26	1.20
5.30			x	4.85	6.45	-	-	-	-	1.20
5.70	x	x		4.60	7.20	5.00	8.90	5.00	10.60	1.20
6.00	x	x		5.06	7.60	5.12	9.40	5.12	11.20	1.20
6.00			x	5.30	7.40	-	-	-	-	1.20
6.99	x	x		6.05	8.75	6.10	10.12	6.10	13.55	1.50
6.99			x	6.22	8.75	-	-	-	-	1.50
8.40		x		7.65	11.10	7.68	13.30	7.68	15.50	1.50
8.40			x	7.85	11.10	-	-	-	-	1.50
8.40	x			7.35	9.10	-	-	-	-	1.50

Surface imperfections

illustration(schematic)	category of surface imperfections	letter symbol	maximum acceptable limits(mm)										
			grade N (general purpose)					grade S (general purpose)					
			cross section					cross section					
			0	2.25	3.15	4.50	6.30	0	2.25	3.15	4.50	6.30	
			2.25	3.15	4.50	2.25	8.00	2.25	3.15	4.50	6.30	8.00	
	off register and mismatch	a	0.08	0.10	0.13	0.15	0.15	0.08	0.08	0.10	0.12	0.13	
	combined flash, offset and parting line projection	b	0.10	0.12	0.14	0.16	0.18	0.10	0.10	0.13	0.15	0.15	
	backrind	c	0.18	0.27	0.36	0.53	0.07	0.10	0.15	0.20	0.20	0.30	
		d	0.08	0.08	0.10	0.10	0.13	0.05	0.08	0.10	0.10	0.13	
	excessive trimming	Departure from a circular cross section due to trimming is permissible providing the resulting surface is smoothly blended and is within the tolerances.											
	flow marks, radial orientation is not permissible	e	0.05*I.D. or					0.03*I.D. or					
		f	1.50	1.50	6.50	6.50	6.50	1.50	1.50	5.00	5.00	5.00	
	foreign materials non fills, indentations, including parting line	g	0.08	0.08	0.08	0.08	0.08	0.05	0.05	0.05	0.05	0.05	
		h	0.60	0.80	1.00	1.30	1.70	0.15	0.25	0.40	0.63	1.00	
			0.08	0.08	0.10	0.10	0.13	0.08	0.08	0.10	0.10	0.13	

Dimensional tolerances

Dimensional tolerances(DIN 3771/1, ISO 3601/1)

ID	Cross section					ID	Cross section					ID	Cross section				
(mm)	1.80+/-0.08	2.65+/-0.09	3.55+/-0.10	5.30+/-0.13	7.00+/-0.15	(mm)	1.80+/-0.08	2.65+/-0.09	3.55+/-0.10	5.30+/-0.13	7.00+/-0.15	(mm)	1.80+/-0.08	2.65+/-0.09	3.55+/-0.10	5.30+/-0.13	7.00+/-0.15
Toll						Toll						Toll					
±						±						±					
(mm)						(mm)						(mm)					
1.80	0.13	-	-	-	-	36.50	-	0.35	0.35	-	-	165.00	-	-	1.31	1.31	-
2.00	0.13	-	-	-	-	37.50	-	0.36	0.36	-	-	170.00	-	-	1.34	1.34	-
2.24	0.13	-	-	-	-	38.70	-	0.37	0.37	-	-	175.00	-	-	1.38	1.38	-
2.50	0.13	-	-	-	-	40.00	-	-	0.38	0.38	-	180.00	-	-	1.41	1.41	-
2.80	0.14	-	-	-	-	41.20	-	-	0.39	0.39	-	185.00	-	-	1.44	1.44	-
3.15	0.14	-	-	-	-	42.50	-	-	0.40	0.40	-	190.00	-	-	1.48	1.48	-
3.55	0.14	-	-	-	-	43.70	-	-	0.41	0.41	-	195.00	-	-	1.51	1.51	-
3.75	0.14	-	-	-	-	45.00	-	-	0.42	0.42	-	200.00	-	-	1.55	1.55	-
4.00	0.14	-	-	-	-	46.20	-	-	0.43	0.43	-	206.00	-	-	-	1.59	1.59
4.50	0.14	-	-	-	-	47.50	-	-	0.44	0.44	-	212.00	-	-	-	1.63	1.63
4.87	0.15	-	-	-	-	48.70	-	-	0.45	0.45	-	218.00	-	-	-	1.67	1.67
5.00	0.15	-	-	-	-	50.00	-	-	0.46	0.46	-	224.00	-	-	-	1.71	1.71
5.15	0.15	-	-	-	-	51.50	-	-	0.47	0.47	-	230.00	-	-	-	1.75	1.75
5.30	0.15	-	-	-	-	53.00	-	-	0.48	0.48	-	236.00	-	-	-	1.79	1.79
5.60	0.15	-	-	-	-	54.50	-	-	0.50	0.50	-	243.00	-	-	-	1.83	1.83
6.00	0.15	-	-	-	-	56.00	-	-	0.51	0.51	-	250.00	-	-	-	1.88	1.88
6.30	0.15	-	-	-	-	58.00	-	-	0.52	0.52	-	258.00	-	-	-	1.93	1.93
6.70	0.16	-	-	-	-	60.00	-	-	0.54	0.54	-	265.00	-	-	-	1.98	1.98
6.90	0.16	-	-	-	-	61.50	-	-	0.55	0.55	-	272.00	-	-	-	2.02	2.02
7.10	0.16	-	-	-	-	63.00	-	-	0.56	0.56	-	280.00	-	-	-	2.08	2.08
7.50	0.16	-	-	-	-	65.00	-	-	0.58	0.58	-	290.00	-	-	-	2.14	2.14
8.00	0.16	-	-	-	-	67.00	-	-	0.59	0.59	-	300.00	-	-	-	2.21	2.21
8.50	0.16	-	-	-	-	69.00	-	-	0.61	0.61	-	307.00	-	-	-	2.25	2.25
8.76	0.17	-	-	-	-	71.00	-	-	0.63	0.63	-	315.00	-	-	-	2.30	2.30
9.00	0.17	-	-	-	-	73.00	-	-	0.64	0.64	-	325.00	-	-	-	2.37	2.37
9.50	0.17	-	-	-	-	75.00	-	-	0.66	0.66	-	335.00	-	-	-	2.43	2.43
10.00	0.17	-	-	-	-	77.50	-	-	0.67	0.67	-	345.00	-	-	-	2.49	2.49
10.60	0.18	-	-	-	-	80.00	-	-	0.69	0.69	-	355.00	-	-	-	2.56	2.56
11.20	0.18	-	-	-	-	82.50	-	-	0.71	0.71	-	365.00	-	-	-	2.62	2.62
11.80	0.19	-	-	-	-	85.00	-	-	0.73	0.73	-	375.00	-	-	-	2.68	2.68
12.50	0.19	-	-	-	-	87.50	-	-	0.75	0.75	-	387.00	-	-	-	2.76	2.76
13.20	0.19	-	-	-	-	90.00	-	-	0.77	0.77	-	400.00	-	-	-	2.84	2.84
14.00	0.19	0.19	-	-	-	92.50	-	-	0.79	0.79	-	412.00	-	-	-	-	2.91
15.00	0.20	0.20	-	-	-	95.00	-	-	0.81	0.81	-	425.00	-	-	-	-	2.99
16.00	0.20	0.20	-	-	-	97.50	-	-	0.83	0.83	-	437.00	-	-	-	-	3.07
17.00	0.21	0.21	-	-	-	100.00	-	-	0.84	0.84	-	450.00	-	-	-	-	3.15
18.00	-	0.21	0.21	-	-	103.00	-	-	0.87	0.87	-	462.00	-	-	-	-	3.22
19.00	-	0.22	0.22	-	-	106.00	-	-	0.89	0.89	-	475.00	-	-	-	-	3.30
20.00	-	0.22	0.22	-	-	109.00	-	-	0.91	0.91	-	487.00	-	-	-	-	3.37
21.20	-	0.23	0.23	-	-	112.00	-	-	0.93	0.93	-	500.00	-	-	-	-	3.45
22.40	-	0.24	0.24	-	-	115.00	-	-	0.95	0.95	-	515.00	-	-	-	-	3.54
23.60	-	0.24	0.24	-	-	118.00	-	-	0.97	0.97	-	530.00	-	-	-	-	3.63
25.00	-	0.25	0.25	-	-	122.00	-	-	1.00	1.00	-	545.00	-	-	-	-	3.72
25.80	-	0.26	0.26	-	-	125.00	-	-	1.03	1.03	-	560.00	-	-	-	-	3.81
26.50	-	0.26	0.26	-	-	128.00	-	-	1.05	1.05	-	580.00	-	-	-	-	3.93
28.00	-	0.28	0.28	-	-	132.00	-	-	1.08	1.08	-	600.00	-	-	-	-	4.06
30.00	-	0.29	0.29	-	-	136.00	-	-	1.10	1.10	-	615.00	-	-	-	-	4.13
31.50	-	0.31	0.31	-	-	140.00	-	-	1.13	1.13	-	630.00	-	-	-	-	4.22
32.50	-	0.32	0.32	-	-	145.00	-	-	1.17	1.17	-	650.00	-	-	-	-	4.34
33.50	-	0.32	0.32	-	-	150.00	-	-	1.20	1.20	-	670.00	-	-	-	-	4.46
34.50	-	0.33	0.33	-	-	155.00	-	-	1.24	1.24	-	-	-	-	-	-	-
35.50	-	0.34	0.34	-	-	160.00	-	-	1.27	1.27	-	-	-	-	-	-	-

O-RING—AS

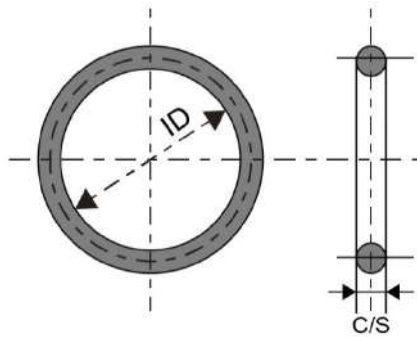

MATERIAL	
NBR	FKM
HNBR	SILICONE

ITEM	ID	C/S	VOL(cm ³)	ITEM	ID	C/S	VOL(cm ³)
* 001	0.74	1.02	0.005	040	72.75	1.78	0.583
* 001 1/2	1.78	1.02	0.007	041	75.92	1.78	0.607
* 002	1.07	1.27	0.009	042	82.27	1.78	0.657
003	1.42	1.52	0.017	043	88.62	1.78	0.707
004	1.78	1.78	0.028	044	94.97	1.78	0.756
005	2.57	1.78	0.034	045	101.32	1.78	0.806
006	2.9	1.78	0.037	046	107.67	1.78	0.856
007	3.68	1.78	0.043	047	114.02	1.78	0.905
008	4.47	1.78	0.049	048	120.37	1.78	0.955
009	5.28	1.78	0.055	049	126.72	1.78	1.005
010	6.07	1.78	0.061	050	133.07	1.78	1.054
011	7.65	1.78	0.074	* 102	1.24	2.62	0.065
012	9.25	1.78	0.086	103	2.05	2.62	0.079
013	10.82	1.78	0.099	104	2.84	2.62	0.092
014	12.42	1.78	0.111	105	3.63	2.62	0.106
015	14	1.78	0.123	106	4.42	2.62	0.119
016	15.6	1.78	0.136	107	5.23	2.62	0.133
017	17.17	1.78	0.148	108	6.02	2.62	0.146
018	18.77	1.78	0.161	109	7.6	2.62	0.173
019	20.35	1.78	0.173	110	9.19	2.62	0.200
020	21.95	1.78	0.186	111	10.77	2.62	0.227
021	23.52	1.78	0.198	112	12.37	2.62	0.254
022	25.12	1.78	0.210	113	13.95	2.62	0.281
023	26.7	1.78	0.223	114	15.54	2.62	0.308
024	28.3	1.78	0.235	115	17.12	2.62	0.334
025	29.87	1.78	0.247	116	18.72	2.62	0.361
026	31.47	1.78	0.260	117	20.29	2.62	0.388
027	33.05	1.78	0.272	118	21.9	2.62	0.415
028	34.65	1.78	0.285	119	23.47	2.62	0.442
029	37.82	1.78	0.310	120	25.07	2.62	0.469
030	41	1.78	0.334	121	26.65	2.62	0.496
031	44.17	1.78	0.359	122	28.25	2.62	0.523
032	47.35	1.78	0.384	123	29.82	2.62	0.549
033	50.52	1.78	0.409	124	31.42	2.62	0.577
034	53.7	1.78	0.434	125	32.99	2.62	0.603
035	56.87	1.78	0.459	126	34.6	2.62	0.630
036	60.05	1.78	0.483	127	36.17	2.62	0.657
037	63.22	1.78	0.508	128	37.77	2.62	0.684
038	66.4	1.78	0.533	129	39.35	2.62	0.711
039	69.57	1.78	0.558	130	40.95	2.62	0.738

O-RING—AS

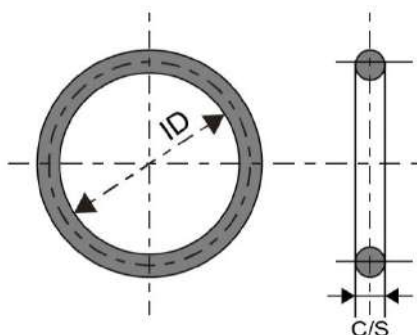

MATERIAL	
NBR	FKM
HNBR	SILICONE

ITEM	ID	C/S	VOL(cm ³)	ITEM	ID	C/S	VOL(cm ³)
131	42.52	2.62	0.765	171	202.8	2.62	3.479
132	44.12	2.62	0.792	172	209.2	2.62	3.588
133	45.7	2.62	0.818	173	215.5	2.62	3.694
134	47.3	2.62	0.846	174	221.9	2.62	3.803
135	48.9	2.62	0.873	175	228.27	2.62	3.911
136	50.47	2.62	0.899	176	234.6	2.62	4.018
137	52.07	2.62	0.926	177	240.9	2.62	4.125
138	53.65	2.62	0.953	178	247.3	2.62	4.233
139	55.25	2.62	0.980	201	4.34	3.53	0.242
140	56.82	2.62	1.007	202	5.94	3.53	0.291
141	58.42	2.62	1.034	203	7.52	3.53	0.340
142	60	2.62	1.061	204	9.12	3.53	0.389
143	61.6	2.62	1.088	205	10.69	3.53	0.437
144	63.17	2.62	1.114	206	12.29	3.53	0.486
145	64.7	2.62	1.140	207	13.87	3.53	0.535
146	66.3	2.62	1.167	208	15.47	3.53	0.584
147	67.9	2.62	1.194	209	17.04	3.53	0.632
148	69.5	2.62	1.222	210	18.64	3.53	0.682
149	71.1	2.62	1.249	211	20.22	3.53	0.730
150	72.7	2.62	1.276	212	21.82	3.53	0.779
151	75.87	2.62	1.329	213	23.4	3.53	0.828
152	82.22	2.62	1.437	214	24.99	3.53	0.877
153	88.57	2.62	1.545	215	26.57	3.53	0.925
154	94.92	2.62	1.652	216	28.17	3.53	0.975
155	101.2	2.62	1.758	217	29.75	3.53	1.023
156	107.62	2.62	1.867	218	31.34	3.53	1.072
157	113.9	2.62	1.974	219	32.92	3.53	1.121
158	120.3	2.62	2.082	220	34.52	3.53	1.170
159	126.6	2.62	2.189	221	36.1	3.53	1.218
160	133.02	2.62	2.297	222	37.69	3.53	1.267
161	139.37	2.62	2.405	223	40.87	3.53	1.365
162	145.7	2.62	2.512	224	44.05	3.53	1.463
163	152	2.62	2.619	225	47.22	3.53	1.560
164	158.42	2.62	2.728	226	50.4	3.53	1.658
165	164.7	2.62	2.834	227	53.57	3.53	1.756
166	171.1	2.62	2.942	228	56.74	3.53	1.853
167	177.4	2.62	3.049	229	59.92	3.53	1.951
168	183.8	2.62	3.157	230	63.1	3.53	2.049
169	190.1	2.62	3.264	231	66.27	3.53	2.146
170	196.5	2.62	3.373	232	69.44	3.53	2.244

O-RING—AS

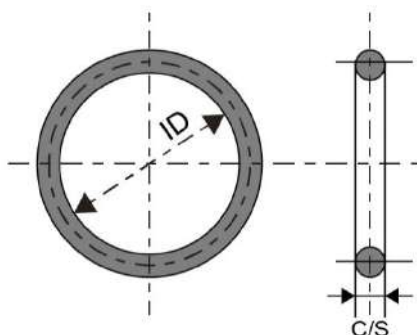

MATERIAL	
NBR	FKM
HNBR	SILICONE

ITEM	ID	C/S	VOL(cm ³)	ITEM	ID	C/S	VOL(cm ³)	
233	72.62	3.53	2.341	273	247.25	3.53	7.711	
234	75.79	3.53	2.439	274	253.6	3.53	7.906	
235	78.97	3.53	2.537	275	266.3	3.53	8.296	
236	82.14	3.53	2.634	276	279	3.53	8.687	
237	85.32	3.53	2.732	277	291.7	3.53	9.077	
238	88.49	3.53	2.829	278	304.39	3.53	9.467	
239	91.67	3.53	2.927	279	329.8	3.53	10.249	
240	94.84	3.53	3.025	280	355.2	3.53	11.030	
241	98.02	3.53	3.122	281	380.6	3.53	11.811	
242	101.19	3.53	3.220	282	405.26	3.53	12.569	
243	104.37	3.53	3.318	283	430.66	3.53	13.350	
244	107.54	3.53	3.415	284	456.06	3.53	14.131	
245	110.72	3.53	3.513	*	309	10.46	5.33	1.107
246	113.89	3.53	3.610	*	310	12.07	5.33	1.220
247	117.07	3.53	3.708	*	311	13.64	5.33	1.330
248	120.24	3.53	3.805		312	15.24	5.33	1.442
249	123.42	3.53	3.903	*	313	16.81	5.33	1.552
250	126.59	3.53	4.001		314	18.42	5.33	1.665
251	129.77	3.53	4.098	*	315	19.99	5.33	1.775
252	132.94	3.53	4.196		316	21.59	5.33	1.887
253	136.12	3.53	4.294		317	23.16	5.33	1.997
254	139.3	3.53	4.391	*	318	24.77	5.33	2.110
255	142.47	3.53	4.489	*	319	26.34	5.33	2.220
256	145.65	3.53	4.587		320	27.94	5.33	2.332
257	148.82	3.53	4.684		321	29.51	5.33	2.442
258	152	3.53	4.782		322	31.12	5.33	2.555
259	158.35	3.53	4.977		323	32.69	5.33	2.665
260	164.7	3.53	5.172		324	34.29	5.33	2.777
261	171.05	3.53	5.368		325	37.46	5.33	2.999
262	177.4	3.53	5.563		326	40.65	5.33	3.223
263	183.75	3.53	5.758		327	43.82	5.33	3.445
264	190.09	3.53	5.953		328	46.99	5.33	3.667
265	196.45	3.53	6.149		329	50.16	5.33	3.890
266	202.8	3.53	6.344		330	53.34	5.33	4.113
267	209.15	3.53	6.539		331	56.52	5.33	4.335
268	215.5	3.53	6.734		332	59.69	5.33	4.558
269	221.85	3.53	6.930		333	62.87	5.33	4.781
270	228.2	3.53	7.125		334	66.04	5.33	5.003
271	234.55	3.53	7.320		335	69.22	5.33	5.226
272	240.9	3.53	7.515		336	72.39	5.33	5.448

O-RING—AS

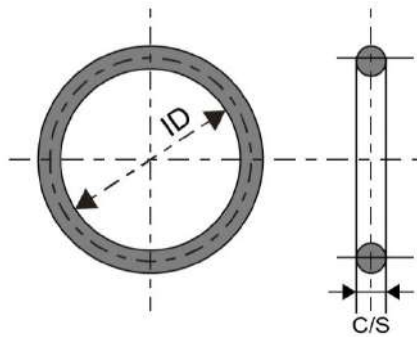

MATERIAL	
NBR	FKM
HNBR	SILICONE

ITEM	ID	C/S	VOL(cm ³)	ITEM	ID	C/S	VOL(cm ³)
337	75.6	5.33	5.673	377	253.37	5.33	18.134
338	78.74	5.33	5.893	378	266.07	5.33	19.024
339	81.92	5.33	6.116	379	278.77	5.33	19.914
340	85.09	5.33	6.338	380	291.47	5.33	20.805
341	88.27	5.33	6.561	381	304.17	5.33	21.695
342	91.44	5.33	6.783	382	329.55	5.33	23.474
343	94.62	5.33	7.006	383	354.97	5.33	25.256
344	97.79	5.33	7.228	384	380.37	5.33	27.036
345	100.96	5.33	7.451	385	405.26	5.33	28.781
346	104.14	5.33	7.673	386	430.65	5.33	30.561
347	107.32	5.33	7.896	387	456.06	5.33	32.342
348	110.49	5.33	8.119	388	481.46	5.33	34.122
349	113.67	5.33	8.341	389	506.85	5.33	35.902
350	116.84	5.33	8.564	390	532.25	5.33	37.682
351	120.02	5.33	8.787	391	557.65	5.33	39.463
352	123.19	5.33	9.009	392	582.65	5.33	41.215
353	126.37	5.33	9.232	393	608.1	5.33	42.999
354	129.54	5.33	9.454	394	633.5	5.33	44.780
355	132.72	5.33	9.677	* 395	658.88	5.33	46.559
356	135.89	5.33	9.899	417	88.27	6.99	11.484
357	139.07	5.33	10.122	419	94.42	6.99	12.226
358	142.24	5.33	10.344	420	97.79	6.98	12.595
359	145.42	5.33	10.567	423	107.32	6.99	13.781
360	148.59	5.33	10.789	425	113.66	6.98	14.503
361	151.77	5.33	11.012	426	116.84	6.98	14.885
362	158.12	5.33	11.457	427	120.02	6.98	15.267
363	164.47	5.33	11.902	428	123.19	6.98	15.648
364	170.82	5.33	12.347	429	126.36	6.98	16.029
365	177.17	5.33	12.793	430	129.54	6.98	16.412
366	183.52	5.33	13.238	431	132.72	6.98	16.794
367	189.87	5.33	13.683	432	135.89	6.98	17.175
368	196.22	5.33	14.128	433	139.06	6.98	17.556
369	202.57	5.33	14.573	434	142.24	6.98	17.938
370	208.92	5.33	15.018	435	145.42	6.98	18.321
371	215.27	5.33	15.463	436	148.59	6.98	18.702
372	221.62	5.33	15.908	437	151.76	6.98	19.083
373	227.97	5.33	16.354	438	158.12	6.98	19.847
374	234.32	5.33	16.799	439	164.46	6.98	20.609
375	240.67	5.33	17.244	440	170.82	6.98	21.374
376	247.02	5.33	17.689	441	177.16	6.98	22.136

O-RING—AS

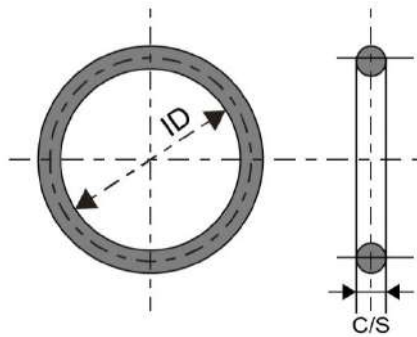

MATERIAL	
NBR	FKM
HNBR	SILICONE

ITEM	ID	C/S	VOL(cm ³)	ITEM	ID	C/S	VOL(cm ³)
442	183.52	6.98	22.901	469	506.86	6.98	61.770
443	189.86	6.98	23.663	470	532.26	6.98	64.824
444	196.22	6.98	24.427	471	557.65	6.98	67.876
445	202.56	6.98	25.190	472	582.68	6.98	70.885
446	215.26	6.98	26.716	473	608.08	6.98	73.938
447	227.96	6.98	28.243	474	633.50	6.98	76.994
448	240.67	6.98	29.771	475	658.88	6.98	80.045
449	253.36	6.98	31.296	901	4.7	1.42	0.030
450	266.06	6.98	32.823	902	6.07	1.63	0.050
451	278.76	6.98	34.350	903	7.65	1.63	0.061
452	291.47	6.98	35.878	904	8.92	1.83	0.089
453	304.16	6.98	37.403	905	10.52	1.83	0.102
454	316.87	6.98	38.931	906	11.89	1.98	0.134
455	329.56	6.98	40.457	907	13.46	2.08	0.166
456	342.27	6.98	41.985	908	16.36	2.21	0.224
457	354.96	6.98	43.510	909	17.94	2.46	0.305
458	367.66	6.98	45.037	910	19.18	2.46	0.323
459	380.36	6.98	46.563	911	21.92	2.95	0.534
460	393.07	6.98	48.091	912	23.47	2.95	0.567
461	405.26	6.98	49.557	913	25.04	2.95	0.601
462	417.96	6.98	51.083	914	26.6	2.95	0.635
463	430.66	6.98	52.610	916	29.74	2.95	0.702
464	443.36	6.98	54.137	918	34.42	2.95	0.802
465	456.06	6.98	55.664	920	37.46	3	0.898
466	468.76	6.98	57.190	924	43.68	3	1.037
467	481.46	6.98	58.717	928	53.09	3	1.246
468	494.16	6.98	60.244	932	59.36	3	1.385

O-RING—P

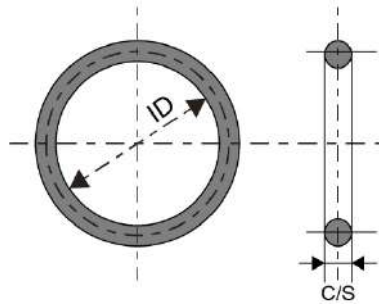

MATERIAL	
NBR	FKM
HNBR	SILICONE

ITEM	ID	C/S	ITEM	ID	C/S
002	1.8	1.9	033	32.7	3.5
003	2.8	1.9	034	33.7	3.5
004	3.8	1.9	035	34.7	3.5
005	4.8	1.9	35.5	35.2	3.5
006	5.8	1.9	036	35.7	3.5
007	6.8	1.9	037	36.7	3.5
008	7.8	1.9	038	37.7	3.5
009	8.8	1.9	039	38.7	3.5
010	9.8	1.9	040	39.7	3.5
010A	9.8	2.4	041	40.7	3.5
011	10.8	2.4	042	41.7	3.5
011.2	11	2.4	* 043	42.7	3.5
012	11.8	2.4	044	43.7	3.5
012.5	12.3	2.4	044A	43.6	5.7
013	12.8	2.4	045	44.7	3.5
014	13.8	2.4	045A	44.6	5.7
015	14.8	2.4	046	45.7	3.5
016	15.8	2.4	046A	45.7	5.7
017	16.8	2.4	047	46.7	3.5
018	17.8	2.4	048	47.7	3.5
019	18.8	2.4	048A	47.6	5.7
020	19.8	2.4	049	48.7	3.5
021	20.8	2.4	050	49.7	3.5
022	21.8	2.4	050A	49.6	5.7
022A	21.7	3.5	044A	43.6	5.7
022B	21.7	3	045A	44.6	5.7
022.4	22.1	3.5	046A	45.7	5.7
* 023	22.7	3.5	048A	47.6	5.7
024	23.7	3.5	050A	49.6	5.7
025	24.7	3.5	052	51.6	5.7
025.5	25.2	3.5	053	52.6	5.7
026	25.7	3.5	055	54.6	5.7
027	26.7	3.5	056	55.6	5.7
028	27.7	3.5	057	56.6	5.7
029	28.7	3.5	058	57.6	5.7
029.5	29.2	3.5	060	59.6	5.7
030	29.7	3.5	062	61.6	5.7
031	30.7	3.5	063	62.6	5.7
031.5	31.2	3.5	065	64.6	5.7
032	31.7	3.5	067	66.6	5.7

O-RING—P

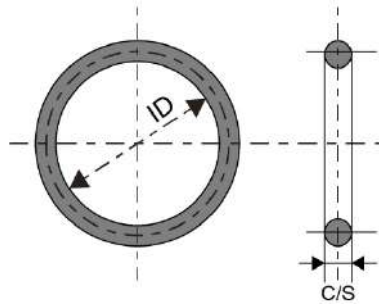

MATERIAL	
NBR	FKM
HNBR	SILICONE

ITEM	ID	C/S	ITEM	ID	C/S
068	67.6	5.7	225	224.5	8.4
070	69.6	5.7	230	229.5	8.4
071	70.6	5.7	235	234.5	8.4
075	74.6	5.7	240	239.5	8.4
080	79.6	5.7	245	244.5	8.4
085	84.6	5.7	250	249.5	8.4
090	89.6	5.7	255	254.5	8.4
095	94.6	5.7	260	259.5	8.4
100	99.6	5.7	265	264.5	8.4
102	101.6	5.7	270	269.5	8.4
105	104.6	5.7	275	274.5	8.4
110	109.6	5.7	280	279.5	8.4
112	111.6	5.7	285	284.5	8.4
115	114.6	5.7	290	289.5	8.4
120	119.6	5.7	295	294.5	8.4
125	124.6	5.7	300	299.5	8.4
130	129.6	5.7	305	304.5	8.4
132	131.6	5.7	310	309.5	8.4
135	134.6	5.7	315	314.5	8.4
140	139.6	5.7	320	319.5	8.4
145	144.6	5.7	325	324.5	8.4
145A	114.5	8.4	330	329.5	8.4
150	149.6	5.7	335	334.5	8.4
145A	144.5	8.4	340	339.5	8.4
150A	149.5	8.4	345	344.5	8.4
155	154.5	8.4	350	349.5	8.4
160	159.5	8.4	355	354.5	8.4
165	164.5	8.4	360	359.5	8.4
170	169.5	8.4	365	364.5	8.4
175	174.5	8.4	370	369.5	8.4
180	179.5	8.4	375	374.5	8.4
185	184.5	8.4	380	379.5	8.4
190	189.5	8.4	385	384.5	8.4
195	194.5	8.4	390	389.5	8.4
200	199.5	8.4	395	394.5	8.4
205	204.5	8.4	400	399.5	8.4
209	208.5	8.4	405	404.5	8.4
210	209.5	8.4	410	409.5	8.4
215	214.5	8.4	415	414.5	8.4
220	219.5	8.4	420	419.5	8.4

O-RING—P

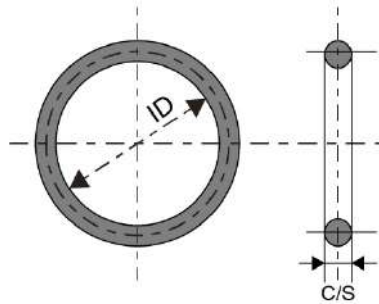

MATERIAL	
NBR	FKM
HNBR	SILICONE

ITEM	ID	C/S	ITEM	ID	C/S		
425	424.5	8.4	630	629.5	8.4		
430	429.5	8.4	635	634.5	8.4		
435	434.5	8.4	640	639.5	8.4		
440	439.5	8.4	645	644.5	8.4		
445	444.5	8.4	650	649.5	8.4		
450	449.5	8.4	*	660	659.5	8.4	
455	454.5	8.4	665	664.5	8.4		
460	459.5	8.4	670	669.5	8.4		
465	464.5	8.4	675	674.5	8.4		
470	469.5	8.4	680	679.5	8.4		
475	474.5	8.4	685	684.5	8.4		
480	479.5	8.4	*	690	689.5	8.4	
485	484.5	8.4	695	694.5	8.4		
490	489.5	8.4	700	699.5	8.4		
495	494.5	8.4	705	704.5	8.4		
500	499.5	8.4	710	709.5	8.4		
505	504.5	8.4	715	715	8.4		
510	509.5	8.4	*	720	719.5	8.4	
515	514.5	8.4	730	729.5	8.4		
520	519.5	8.4	735	734.5	8.4		
525	524.5	8.4	740	739.5	8.4		
530	529.5	8.4	750	749.5	8.4		
535	534.5	8.4	755	754.5	8.4		
540	539.5	8.4	*	760	759.5	8.4	
545	544.5	8.4	765	764.5	8.4		
550	549.5	8.4	770	769.5	8.4		
*	555	554.5	8.4	775	774.5	8.4	
560	559.5	8.4	780	779.5	8.4		
565	564.5	8.4	785	784.5	8.4		
570	569.5	8.4	*	790	789.5	8.4	
575	574.5	8.4	800	799.5	8.4		
580	579.5	8.4	*	810	809.5	8.4	
585	584.5	8.4	815	814.5	8.4		
590	589.5	8.4	*	820	819.5	8.4	
*	595	594.5	8.4	825	824.5	8.4	
600	599.5	8.4	*	830	829.5	8.4	
605	604.5	8.4	835	834.5	8.4		
610	609.5	8.4	*	840	839.5	8.4	
615	615	8.4	850	849.5	8.4		
*	620	619.5	8.4	*	860	859.5	8.4

O-RING—P

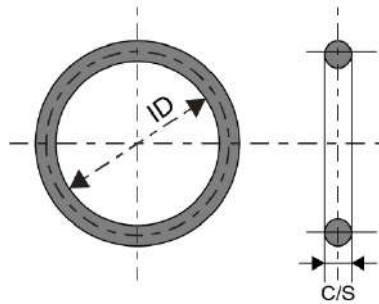

MATERIAL	
NBR	FKM
HNBR	SILICONE

ITEM	ID	C/S	ITEM	ID	C/S
865	865	8.4	* 1120	1119.5	8.4
* 870	869.5	8.4	* 1140	1139.5	8.4
* 880	879.5	8.4	* 1160	1159.5	8.4
* 890	889.5	8.4	* 1180	1179.5	8.4
885	884.5	8.4	* 1200	1199.5	8.4
900	899.5	8.4	* 1220	1219.5	8.4
* 910	909.5	8.4	* 1240	1239.5	8.4
* 920	919.5	8.4	* 1260	1259.5	8.4
* 930	929.5	8.4	* 1280	1279.5	8.4
* 940	939.5	8.4	* 1300	1299.5	8.4
* 950	949.5	8.4	* 1320	1319.5	8.4
* 960	959.5	8.4	* 1340	1339.5	8.4
* 970	969.5	8.4	* 1360	1359.5	8.4
* 980	979.5	8.4	* 1380	1379.5	8.4
* 990	989.5	8.4	* 1400	1399.5	8.4
* 1000	999.5	8.4	* 1420	1419.5	8.4
* 1020	1019.5	8.4	* 1440	1439.5	8.4
* 1040	1039.5	8.4	* 1460	1459.5	8.4
* 1060	1059.5	8.4	* 1480	1479.5	8.4
* 1080	1079.5	8.4	* 1500	1499.5	8.4
* 1100	1099.5	8.4			

O-RING—G

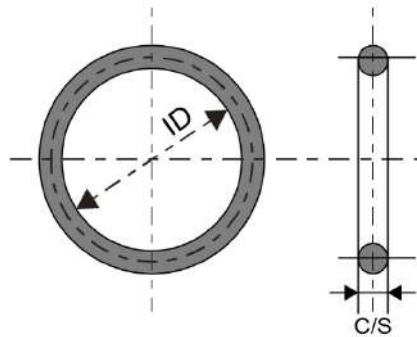

MATERIAL	
NBR	FKM
HNBR	SILICONE

ITEM	ID	C/S	VOL(cm ³)	ITEM	ID	C/S	VOL(cm ³)
* 003	2.4	3.1	0.130	* 043	42.4	3.1	1.079
* 004	3.4	3.1	0.154	* 044	43.4	3.1	1.103
* 005	4.4	3.1	0.178	045	44.4	3.1	1.126
* 006	5.4	3.1	0.202	* 046	45.4	3.1	1.150
* 007	6.4	3.1	0.225	047	46.4	3.1	1.174
* 008	7.4	3.1	0.249	* 048	47.4	3.1	1.197
* 009	8.4	3.1	0.273	* 049	48.4	3.1	1.221
* 010	9.4	3.1	0.296	050	49.4	3.1	1.245
* 011	10.4	3.1	0.320	052	51.4	3.1	1.292
* 012	11.4	3.1	0.344	055	54.4	3.1	1.363
* 013	12.4	3.1	0.368	058	57.4	3.1	1.435
* 014	13.4	3.1	0.391	060	59.4	3.1	1.482
* 015	14.4	3.1	0.415	* 062	61.4	3.1	1.529
* 016	15.4	3.1	0.439	063	62.4	3.1	1.553
* 017	16.4	3.1	0.462	* 064	63.4	3.1	1.577
* 018	17.4	3.1	0.486	065	64.4	3.1	1.601
* 019	18.4	3.1	0.510	* 067	66.4	3.1	1.648
* 020	19.4	3.1	0.534	068	67.4	3.1	1.672
* 021	20.4	3.1	0.557	070	69.4	3.1	1.719
* 022	21.4	3.1	0.581	* 072	71.4	3.1	1.767
* 023	22.4	3.1	0.605	075	74.4	3.1	1.838
* 024	23.4	3.1	0.628	080	79.4	3.1	1.956
025	24.4	3.1	0.652	085	84.4	3.1	2.075
* 026	25.4	3.1	0.676	087	86.4	3.1	2.122
* 027	26.4	3.1	0.699	090	89.4	3.1	2.193
* 028	27.4	3.1	0.723	095	94.4	3.1	2.312
* 029	28.4	3.1	0.747	100	99.4	3.1	2.430
030	29.4	3.1	0.771	105	104.4	3.1	2.549
* 031	30.4	3.1	0.794	110	109.4	3.1	2.668
* 032	31.4	3.1	0.818	115	114.4	3.1	2.786
* 033	32.4	3.1	0.842	120	119.4	3.1	2.905
* 034	33.4	3.1	0.865	125	124.4	3.1	3.023
035	34.4	3.1	0.889	130	129.4	3.1	3.142
* 036	35.4	3.1	0.913	135	134.4	3.1	3.260
* 037	36.4	3.1	0.937	140	139.4	3.1	3.379
* 038	37.4	3.1	0.960	145	144.4	3.1	3.497
* 039	38.4	3.1	0.984	150	149.3	5.7	12.426
040	39.4	3.1	1.008	155	154.3	5.7	12.827
* 041	40.4	3.1	1.031	160	159.3	5.7	13.227
042	41.4	3.1	1.055	165	164.3	5.7	13.628

O-RING—G

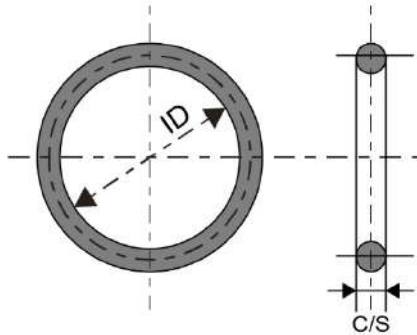

MATERIAL	
NBR	FKM
HNBR	SILICONE

ITEM	ID	C/S	VOL(cm ³)	ITEM	ID	C/S	VOL(cm ³)
170	169.3	5.7	14.029	365	364.3	5.7	29.662
175	174.3	5.7	14.430	370	369.3	5.7	30.062
180	179.3	5.7	14.831	375	374.3	5.7	30.463
185	184.3	5.7	15.232	380	379.3	5.7	30.864
190	189.3	5.7	15.632	385	384.3	5.7	31.265
195	194.3	5.7	16.033	390	389.3	5.7	31.666
200	199.3	5.7	16.434	395	394.3	5.7	32.066
205	204.3	5.7	16.835	400	399.3	5.7	32.467
210	209.3	5.7	17.236	405	404.3	5.7	32.868
215	214.3	5.7	17.637	410	409.3	5.7	33.269
217	216.3	5.7		415	414.3	5.7	33.670
220	219.3	5.7	18.037	420	419.3	5.7	34.071
225	224.3	5.7	18.438	425	424.3	5.7	34.471
230	229.3	5.7	18.839	430	429.3	5.7	34.872
235	234.3	5.7	19.240	435	434.3	5.7	35.273
240	239.3	5.7	19.641	440	439.3	5.7	35.674
245	244.3	5.7	20.042	445	444.3	5.7	36.075
250	249.3	5.7	20.442	450	449.3	5.7	36.476
255	254.3	5.7	20.843	455	454.3	5.7	36.876
260	259.3	5.7	21.244	460	459.3	5.7	37.277
265	264.3	5.7	21.645	465	464.3	5.7	37.678
270	269.3	5.7	22.046	470	469.3	5.7	38.079
275	274.3	5.7	22.447	475	474.3	5.7	38.480
280	279.3	5.7	22.847	480	479.3	5.7	38.881
* 285	284.3	5.7	23.248	485	484.3	5.7	39.281
290	289.3	5.7	23.649	490	489.3	5.7	39.682
295	294.3	5.7	24.050	495	494.3	5.7	40.083
300	299.3	5.7	24.451	500	499.3	5.7	40.484
305	304.3	5.7	24.852	* 505	504.3	5.7	40.885
310	309.3	5.7	25.252	510	509.3	5.7	41.286
315	314.3	5.7	25.653	515	514.3	5.7	41.686
320	319.3	5.7	26.054	520	519.3	5.7	42.087
325	324.3	5.7	26.455	525	524.3	5.7	42.488
330	329.3	5.7	26.856	530	529.3	5.7	42.889
335	334.3	5.7	27.257	* 535	534.3	5.7	43.290
340	339.3	5.7	27.657	540	539.3	5.7	43.691
345	344.3	5.7	28.058	* 545	544.3	5.7	44.091
350	349.3	5.7	28.459	550	549.3	5.7	44.492
355	354.3	5.7	28.860	* 555	554.3	5.7	44.893
360	359.3	5.7	29.261	* 560	559.3	5.7	45.294

O-RING—G

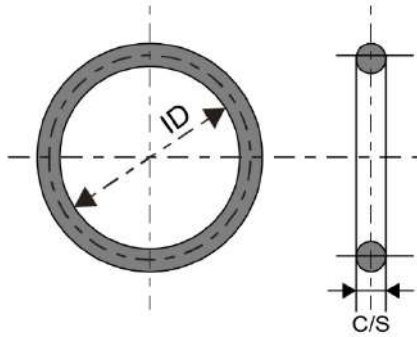

MATERIAL	
NBR	FKM
HNBR	SILICONE

ITEM	ID	C/S	VOL(cm ³)	ITEM	ID	C/S	VOL(cm ³)
* 565	564.3	5.7	45.695	* 735	734.3	5.7	59.323
570	569.3	5.7	46.096	* 740	739.3	5.7	59.724
575	574.3	5.7	46.496	* 745	744.3	5.7	60.125
580	579.3	5.7	46.897	* 750	749.3	5.7	60.526
585	584.3	5.7	47.298	* 755	754.3	5.7	60.926
590	589.3	5.7	47.699	* 760	759.3	5.7	61.327
* 595	594.3	5.7	48.100	* 765	764.3	5.7	61.728
* 600	599.3	5.7	48.501	* 770	769.3	5.7	62.129
* 605	604.3	5.7	48.901	* 775	774.3	5.7	62.530
610	609.3	5.7	49.302	* 780	779.3	5.7	62.930
* 615	614.3	5.7	49.703	* 785	784.3	5.7	63.331
* 620	619.3	5.7	50.104	* 790	789.3	5.7	63.732
* 625	624.3	5.7	50.505	* 795	794.3	5.7	64.133
* 630	629.3	5.7	50.906	* 800	799.3	5.7	64.534
* 635	634.3	5.7	51.306	* 810	809.3	5.7	65.335
640	639.3	5.7	51.707	* 820	819.3	5.7	66.137
* 645	644.3	5.7	52.108	* 830	829.3	5.7	66.939
* 650	649.3	5.7	52.509	* 840	839.3	5.7	67.740
* 655	654.3	5.7	52.910	* 850	849.3	5.7	68.542
660	659.3	5.7	53.311	* 860	859.3	5.7	69.344
665	664.3	5.7	53.711	* 870	869.3	5.7	70.145
* 670	669.3	5.7	54.112	* 880	879.3	5.7	70.947
* 675	674.3	5.7	54.513	* 890	889.3	5.7	71.749
* 680	679.3	5.7	54.914	* 900	899.3	5.7	72.550
* 685	684.3	5.7	55.315	* 910	909.3	5.7	73.352
690	689.3	5.7	55.716	* 920	919.3	5.7	74.154
* 695	694.3	5.7	56.116	* 930	929.3	5.7	74.955
* 700	699.3	5.7	56.517	* 940	939.3	5.7	75.757
* 705	704.3	5.7	56.918	* 950	949.3	5.7	76.559
710	709.3	5.7	57.319	* 960	959.3	5.7	77.360
* 715	714.3	5.7	57.720	* 970	969.3	5.7	78.162
* 720	719.3	5.7	58.121	* 980	979.3	5.7	78.964
* 725	724.3	5.7	58.521	* 990	989.3	5.7	79.765
* 730	729.3	5.7	58.922				

O-RING—GS

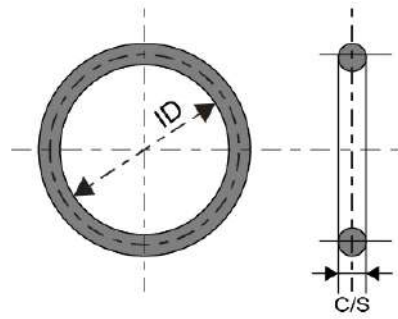

MATERIAL	
NBR	FKM
HNBR	SILICONE

ITEM	ID	C/S	VOL(cm ³)	ITEM	ID	C/S	VOL(cm ³)
150	149.3	3.1	3.614	285	284.3	3.1	6.815
155	154.3	3.1	3.732	290	289.3	3.1	6.933
160	159.3	3.1	3.851	295	294.3	3.1	7.052
162	161.3	3.1	3.898	300	299.3	3.1	7.170
165	164.3	3.1	3.969	305	304.3	3.1	7.289
170	169.3	3.1	4.088	310	309.3	3.1	7.408
175	174.3	3.1	4.206	315	314.3	3.1	7.526
180	179.3	3.1	4.325	320	319.3	3.1	7.645
185	184.3	3.1	4.444	330	329.3	3.1	7.882
190	189.3	3.1	4.562	340	339.3	3.1	8.119
195	194.3	3.1	4.681	350	349.3	3.1	8.356
200	199.3	3.1	4.799	355	354.3	3.1	8.475
205	204.3	3.1	4.918	360	359.3	3.1	8.593
210	209.3	3.1	5.036	365	364.3	3.1	8.712
215	214.3	3.1	5.155	370	369.3	3.1	8.830
220	219.3	3.1	5.274	380	379.3	3.1	9.067
225	224.3	3.1	5.392	400	399.3	3.1	9.542
230	229.3	3.1	5.511	406	405.3	3.1	9.684
232	231.3	3.1	5.558	410	409.3	3.1	9.779
235	234.3	3.1	5.629	415	414.3	3.1	9.897
240	239.3	3.1	5.748	420	419.3	3.1	10.016
245	244.3	3.1	5.866	430	429.3	3.1	10.253
250	249.5	3.1	5.990	440	439.3	3.1	10.490
255	254.3	3.1	6.103	450	449.3	3.1	10.727
260	259.3	3.1	6.222	460	459.3	3.1	10.964
265	264.3	3.1	6.341	470	469.3	3.1	11.201
270	269.3	3.1	6.459	480	479.3	3.1	11.439
275	274.3	3.1	6.578	490	489.3	3.1	11.676
280	279.3	3.1	6.696	500	499.3	3.1	11.913

O-RING—S

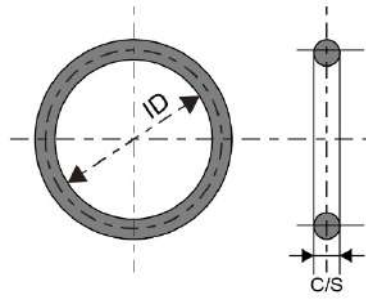

MATERIAL	
NBR	FKM
HNBR	SILICONE

ITEM	ID	C/S	VOL(cm ³)	ITEM	ID	C/S	VOL(cm ³)
003	2.5	1.5	0.022	045	44.5	2	0.459
004	3.5	1.5	0.028	046	45.5	2	0.469
005	4.5	1.5	0.033	048	47.5	2	0.489
006	5.5	1.5	0.039	050	49.5	2	0.508
007	6.5	1.5	0.044	053	52.5	2	0.538
008	7.5	1.5	0.050	055	54.5	2	0.558
009	8.5	1.5	0.056	056	55.5	2	0.568
010	9.5	1.5	0.061	060	59.5	2	0.607
011.2	10.7	1.5	0.068	063	62.5	2	0.637
012	11.5	1.5	0.072	065	64.5	2	0.656
012.5	12	1.5	0.075	067	66.5	2	0.676
014	13.5	1.5	0.083	070	69.5	2	0.706
015	14.5	1.5	0.089	071	70.5	2	0.716
016	15.5	1.5	0.094	075	74.5	2	0.755
017	16.5	1.5	0.100	080	79.5	2	0.804
018	17.5	1.5	0.105	085	84.5	2	0.854
020	19.5	1.5	0.117	090	89.5	2	0.903
* 021	20.8	1.5	0.124	095	94.5	2	0.952
022	21.5	1.5	0.128	100	99.5	2	1.002
022.4	21.9	2	0.236	105	104.5	2	1.051
024	23.5	2	0.252	110	109.5	2	1.100
025	24.5	2	0.262	112	111.5	2	1.120
026	25.5	2	0.271	115	114.5	2	1.150
028	27.5	2	0.291	120	119.5	2	1.199
029	28.5	2	0.301	125	124.5	2	1.249
030	29.5	2	0.311	130	129.5	2	1.298
031.5	31	2	0.326	132	131.5	2	1.318
032	31.5	2	0.331	135	134.5	2	1.347
034	33.5	2	0.350	140	139.5	2	1.397
035	34.5	2	0.360	145	144.5	2	1.446
035.5	35	2	0.365	150	149.5	2	1.495
036	35.5	2	0.370	155	154.5	2	1.545
037	36.5	2	0.380	160	159.5	2	1.594
038	37.5	2	0.390	165	164.5	2	1.643
039	38.5	2	0.400	170	169.5	2	1.693
040	39.5	2	0.410	* 175	174.5	2	1.742
042	41.5	2	0.429	180	179.5	2	1.791
044	43.5	2	0.449	185	184.5	2	1.841

O-RING—V

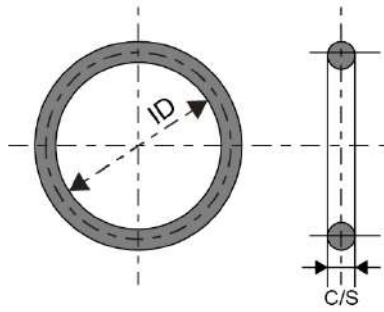

MATERIAL	
NBR	FKM
HNBR	SILICONE

ITEM	ID	C/S	VOL(cm ³)
225	222.5	6	20.297
275	272	6	24.694
325	321.5	6	29.091
380	376	6	33.932
430	425.5	6	38.329
* 480	475.5	10	119.793
* 530	524.5	10	131.883
* 580	579	10	145.331
* 640	633.5	10	158.778
690	683	10	170.992
* 740	732.5	10	183.205
* 790	782	10	195.419
* 845	836.5	10	208.866
* 950	940.5	10	234.528
* 1055	1044	10	260.065

PETSEALS

O-RING—JASO 1000

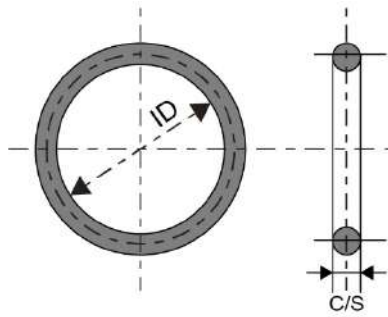

MATERIAL	
NBR	FKM
HNBR	SILICONE

ITEM	ID	OD	C/S	VOL(cm ³)	REMARK
1003	2.8		1.9	0.042	P-003
1004	3.8		1.9	0.051	P-004
1005	4.8		1.9	0.060	P-005
1006	5.8		1.9	0.069	P-006
1007	6.8		1.9	0.077	P-007
1008	7.8		1.9	0.086	P-008
1009	8.8		1.9	0.095	P-009
1010	9.8		1.9	0.104	P-010
1011	11		1.9	0.115	
1012	12.3		1.9	0.126	
1013	13		1.9	0.133	
1014	13.8		1.9	0.140	
1015	14.8		1.9	0.149	
1016	15.8		1.9	0.158	
1017	16.8		1.9	0.167	
1018	17.8		1.9	0.175	
1019	18.8		1.9	0.184	
1020	19.8		1.9	0.193	
1021	21		1.9	0.204	
1022	22.1		1.9	0.214	
1023	23.3		1.9	0.224	
1025	24.7		1.9	0.237	
1026	26.2		1.9	0.250	
1028	27.7		1.9	0.264	
1030	29.7		1.9	0.281	
1031	31.2		1.9	0.295	
1033	33.2		1.9	0.313	
1035	35.2		1.9	0.330	

O-RING—JASO 2000

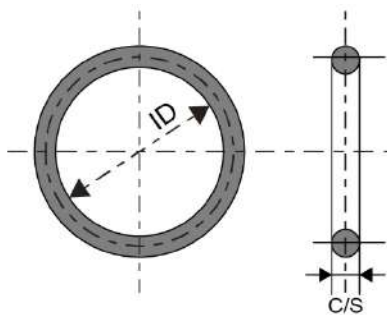

MATERIAL	
NBR	FKM
HNBR	SILICONE

ITEM	ID	OD	C/S	VOL(cm ³)	REMARK
2010	9.8	14.6	2.4	0.173	P-10A
2011	11	15.8	2.4	0.190	P-011.2
2012	12.3	17.1	2.4	0.209	P-012.5
2013	13	17.8	2.4	0.219	13*2.5
2014	13.8	18.6	2.4	0.230	P-014
2015	14.8	19.6	2.4	0.244	P-015
2016	15.8	20.6	2.4	0.259	P-016
2017	16.8	21.6	2.4	0.273	P-017
2018	17.8	22.6	2.4	0.287	P-018
2019	18.8	23.6	2.4	0.301	P-019
2020	19.8	24.6	2.4	0.316	P-020
2021	20.8	25.6	2.4	0.330	P-021
2022	22.1	26.9	2.4	0.348	
2023	23.3	28.1	2.4	0.365	
2025	24.7	29.5	2.4	0.385	
2026	26.2	31	2.4	0.406	
2028	27.7	32.5	2.4	0.428	
2030	29.7	34.5	2.4	0.456	
2031	31.2	36	2.4	0.478	
2033	33.2	38	2.4	0.506	
2035	35.2	40	2.4	0.534	
2037	37.2	42	2.4	0.563	
2040	39.7	44.5	2.4	0.598	
2042	42.2	47	2.4	0.634	
2045	44.7	49.5	2.4	0.669	
2047	47.2	52	2.4	0.705	
2050	49.7	54.5	2.4	0.740	
2053	52.6	57.4	2.4	0.782	
2056	55.6	60.4	2.4	0.824	
2060	59.6	64.4	2.4	0.881	
2063	62.6	67.4	2.4	0.924	
2065	64.6	69.4	2.4	0.952	
2067	66.6	71.4	2.4	0.981	
2071	70.6	75.4	2.4	1.037	

O-RING—JASO 3000

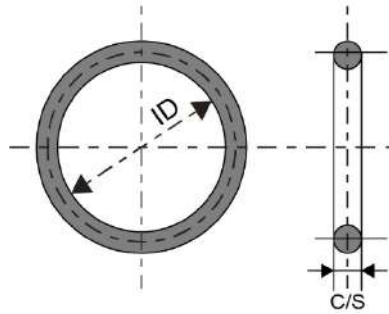

MATERIAL	
NBR	FKM
HNBR	SILICONE

ITEM	ID	OD	C/S	VOL(cm ³)	REMARK
3022	22.1	29.1	3.5	0.774	P-022.4
3024	23.7	30.7	3.5	0.822	P-024
3025	24.7	31.7	3.5	0.852	P-025
3026	25.7	32.7	3.5	0.883	P-026
3028	27.7	34.7	3.5	0.943	P-028
3030	29.7	36.7	3.5	1.003	P-030
3031	31.2	38.2	3.5	1.049	P-031.5
3034	33.7	40.7	3.5	1.124	P-034
3035	35.2	42.2	3.5	1.170	P-035.5
3038	37.7	44.7	3.5	1.245	P-038
3039	38.7	45.7	3.5	1.276	P-039
3040	39.7	46.7	3.5	1.306	P-040
3042	41.7	48.7	3.5	1.366	P-042
3044	43.7	50.7	3.5	1.427	P-044
3045	44.7	51.7	3.5	1.457	P-048
3048	47.7	54.7	3.5	1.548	P-050
3050	49.7	56.7	3.5	1.608	
3053	52.6	59.6	3.5	1.696	
3056	55.6	62.6	3.5	1.786	
3060	59.6	66.6	3.5	1.907	
3063	62.6	69.6	3.5	1.998	
3065	64.6	71.6	3.5	2.058	
3067	66.6	73.6	3.5	2.119	
3068	67.6	74.6	3.5	2.149	
3070	69.6	76.6	3.5	2.210	
3071	70.6	77.6	3.5	2.240	
3075	74.6	81.6	3.5	2.361	
3080	79.6	86.6	3.5	2.512	
3085	84.6	91.6	3.5	2.663	
3088	87.6	94.6	3.5	2.754	
3090	89.6	96.6	3.5	2.814	
3092	91.6	98.6	3.5	2.874	
3095	94.6	101.6	3.5	2.965	
3100	99.6	106.6	3.5	3.116	
3105	104.6	111.6	3.5	3.267	
3106	105.6	112.6	3.5	3.298	
3110	109.6	116.6	3.5	3.419	
3112	111.6	118.6	3.5	3.479	
3115	114.6	121.6	3.5	3.570	
3118	117.6	124.6	3.5	3.660	
3125	124.6	131.6	3.5	3.872	
3132	131.6	138.6	3.5	4.084	
3135	134.6	141.6	3.5	4.174	
3140	139.6	146.6	3.5	4.325	
3145	144.6	151.6	3.5	4.476	
3150	149.6	156.6	3.5	4.628	

O-RING—SMS 1586

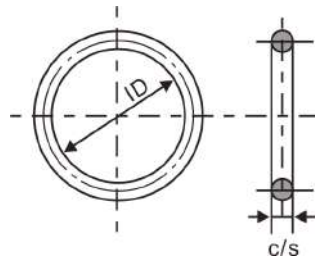

MATERIAL	
NBR	FKM
HNBR	SILICONE

ID	OD	±	C/S	±
3.3	8.1	0.14	2.4	0.09
* 4.3	9.1	0.15	2.4	0.09
* 5.3	10.1	0.15	2.4	0.09
* 6.3	11.1	0.16	2.4	0.09
7.3	12.1	0.17	2.4	0.09
* 8.3	13.1	0.18	2.4	0.09
* 9.3	14.1	0.18	2.4	0.09
* 10.3	15.1	0.19	2.4	0.09
11.3	16.1	0.2	2.4	0.09
12.3	17.1	0.21	2.4	0.09
13.3	18.1	0.22	2.4	0.09
14.3	19.1	0.22	2.4	0.09
15.3	20.1	0.23	2.4	0.09
* 16.3	21.1	0.24	2.4	0.09
* 17.3	22.1	0.25	2.4	0.09
* 18.3	23.1	0.25	2.4	0.09
* 19.3	24.1	0.26	2.4	0.09
20.3	25.1	0.27	2.4	0.09
21.3	26.1	0.27	2.4	0.09
* 22.3	27.1	0.28	2.4	0.09
23.3	28.1	0.29	2.4	0.09
25.3	30.1	0.30	2.4	0.09
* 27.3	32.1	0.32	2.4	0.09
* 30.3	35.1	0.34	2.4	0.09
33.3	38.1	0.36	2.4	0.09
* 12.1	15.3	0.21	1.6	0.08
* 16.1	19.3	0.24	1.6	0.08
* 42.2	48.2	0.42	3	0.09

ISO 6149

Metric Tube Fitting O-Rings

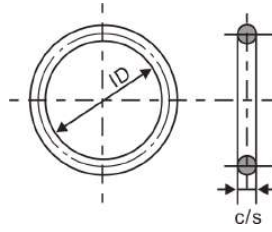

MATERIAL	
NBR	FKM

ID	±	C/S	±	THREAD(METRIC)
* 6.1	0.16	1.6	0.08	M8 x 1
* 8.1	0.18	1.6	0.08	M10 x 1
9.3	0.18	2.2	0.08	M12 x 1.5
* 11.3	0.20	2.2	0.08	M14 x 1.5
* 13.3	0.22	2.2	0.08	M16 x 1.5
15.3	0.23	2.2	0.08	M18 x 1.5
17.3	0.25	2.2	0.08	M20 x 1.5
19.3	0.26	2.2	0.08	M22 x 1.5
* 22.6	0.24	2.9	0.08	M26 x 1.5
* 23.6	0.29	2.9	0.09	M27 x 2
* 26.6	0.26	2.9	0.09	M30 x 2
* 29.6	0.33	2.9	0.09	M33 x 2
* 34.6	0.33	2.9	0.09	M38 x 2
* 38.6	0.40	2.9	0.09	M42 x 2
* 41.60	0.4	2.9	0.09	M45 x 2
* 44.6	0.44	2.9	0.09	M48 x 2
* 56.6	0.53	2.9	0.09	M60 x 2

PET SEALS

O-RING—ISO

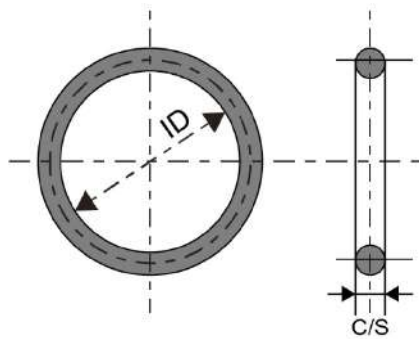

MATERIAL	
NBR	FKM

ITEM	ID	C/S	ITEM	ID	C/S
* ISO-1.8	1.8	1.8	* ISO-12.8	12.8	1.8
* ISO-2.0	2.0	1.8	ISO-13	13.0	1.8
* ISO-2.24	2.2	1.8	ISO-13.2	13.2	1.8
* ISO-2.5	2.5	1.8	* ISO-14	14.0	1.8
* ISO-2.8	2.8	1.8	ISO-15	15.0	1.8
ISO-3.15	3.2	1.8	* ISO-16	16.0	1.8
* ISO-3.55	3.6	1.8	* ISO-17	17.0	1.8
* ISO-3.75	3.8	1.8	ISO-37.5	37.5	1.8
* ISO-4.0	4.0	1.8	* ISO-3.15	3.2	1.8
* ISO-4.5	4.5	1.8	* ISO-6.7	6.7	1.8
* ISO-4.87	4.9	1.8	* ISO-7.5	7.5	1.8
* ISO-5.0	5.0	1.8	* ISO-8.75	8.8	1.8
* ISO-5.15	5.2	1.8	* ISO-9.5	9.5	1.8
* ISO-5.3	5.3	1.8	* ISO-10	10.0	1.8
* ISO-5.6	5.6	1.8	* ISO-11.8	11.8	1.8
ISO-6.0	6.0	1.8	* ISO-13.2	13.2	1.8
* ISO-6.3	6.3	1.8	* ISO-18	18.0	1.8
ISO-6.7	6.7	1.8	* ISO-19	19.0	1.8
* ISO-6.9	6.9	1.8	* ISO-20	20.0	1.8
* ISO-7.1	7.1	1.8	* ISO-21.2	21.2	1.8
ISO-7.5	7.5	1.8	* ISO-22.4	22.4	1.8
ISO-8.0	8.0	1.8	* ISO-23.6	23.6	1.8
* ISO-8.5	8.5	1.8	* ISO-25	25.0	1.8
ISO-8.75	8.8	1.8	* ISO-26.5	26.5	1.8
ISO-9.0	9.0	1.8	* ISO-28	28.0	1.8
ISO-9.5	9.5	1.8	* ISO-30	30.0	1.8
* ISO-9.75	9.8	1.8	* ISO-32.5	32.5	1.8
ISO-10	10.0	1.8	* ISO-34.5	34.5	1.8
* ISO-10.6	10.6	1.8	* ISO-36.5	36.5	1.8
ISO-11.2	11.2	1.8	* ISO-38.7	38.7	1.8
* ISO-11.6	11.6	1.8	* ISO-42.5	42.5	1.8
ISO-11.8	11.8	1.8	* ISO-46.2	46.2	1.8
* ISO-12.1	12.1	1.8	* ISO-50	50.0	1.8
* ISO-12.5	12.5	1.8	* ISO-85	85.0	1.8

O-RING—1mm / SS

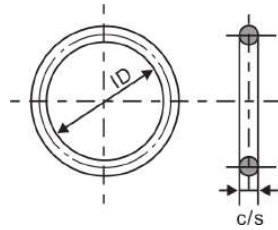

MATERIAL	
NBR	FKM
HNBR	SILICONE

ID	OD	C/S	VOL(cm ³)	SS系列	ID	OD	C/S	VOL(cm ³)	SS系列
2.0	4.0	1	0.007	SS	12	14	1	0.032076	
* 2.5	4.5	1	0.009	SS	13	15	1	0.034544	
3.0	5.0	1	0.010	SS	14	16	1	0.037011	
3.5	5.5	1	0.011	SS	15	17	1	0.039479	
4.0	6.0	1	0.012	SS	16	18	1	0.041946	
4.5	6.5	1	0.014	SS	17	19	1	0.044413	
5.0	7.0	1	0.015	SS	18	20	1	0.046881	
* 5.5	7.5	1	0.016	SS	19	21	1	0.049348	
6.0	8.0	1	0.017	SS	20	22	1	0.051816	
* 6.5	8.5	1	0.019	SS	22	24	1	0.05675	
7.0	9.0	1	0.020	SS	23	25	1	0.059218	
7.5	9.5	1	0.021	SS	25	27	1	0.064153	
8.0	10.0	1	0.022	SS	27.6	29.6	1	0.070568	
* 8.5	10.5	1	0.023	SS	28	30	1	0.071555	
9.0	11.0	1	0.025	SS	30	32	1	0.07649	
* 9.5	11.5	1	0.026	SS	31.5	33.5	1	0.080191	
10.0	12.0	1	0.027	SS	* 32	34	1	0.081425	
* 10.5	12.5	1	0.028	SS	* 34	36	1	0.086359	
11.0	13.0	1	0.030	SS	37	39	1	0.093762	
* 11.5	13.5	1	0.031	SS	* 40	42	1	0.101164	

O-RING—1.5mm

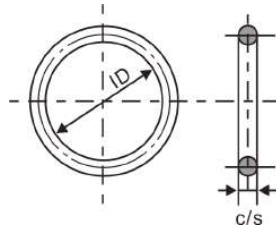

MATERIAL	
NBR	FKM
HNBR	SILICONE

ID	OD	C/S	VOL(cm ³)	ID	OD	C/S	VOL(cm ³)
3	6	1.5	0.025	* 29	32	1.5	0.169
4	7	1.5	0.031	29.5	32.5	1.5	0.172
5	8	1.5	0.036	30	33	1.5	0.175
6	9	1.5	0.042	31	34	1.5	0.180
7	10	1.5	0.047	* 31.5	34.5	1.5	0.183
8	11	1.5	0.053	32	35	1.5	0.186
8.2	11.2	1.5	0.054	33	36	1.5	0.192
9	12	1.5	0.058	38	41	1.5	0.219
10	13	1.5	0.064	* 39.5	42.5	1.5	0.228
10.5	13.5	1.5	0.067	* 40	43	1.5	0.230
11	14	1.5	0.069	41	44	1.5	0.236
12.5	15.5	1.5	0.078	42	45	1.5	0.241
13	16	1.5	0.080	* 45	48	1.5	0.258
14	17	1.5	0.086	* 47.7	50.7	1.5	0.273
15	18	1.5	0.092	48	51	1.5	0.275
17	20	1.5	0.103	* 49.5	52.5	1.5	0.283
18	21	1.5	0.108	50	53	1.5	0.286
18.5	21.5	1.5	0.111	50.3	53.3	1.5	0.288
19	22	1.5	0.114	* 55	58	1.5	0.314
20.5	23.5	1.5	0.122	59	62	1.5	0.336
22.5	25.5	1.5	0.133	60	63	1.5	0.341
23	26	1.5	0.136	62.5	65.5	1.5	0.355
24	27	1.5	0.142	62.7	65.7	1.5	0.356
25	28	1.5	0.147	63	66	1.5	0.358
26	29	1.5	0.153	80	83	1.5	0.452
27	30	1.5	0.158	82	85	1.5	0.464
27.5	30.5	1.5	0.161	* 100	103	1.5	0.563
28	31	1.5	0.164				

O-RING—2mm

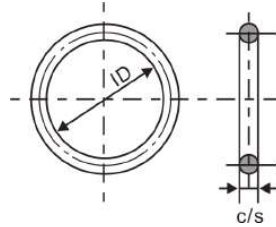

MATERIAL	
NBR	FKM
HNBR	SILICONE

ID	OD	C/S	VOL(cm ³)	ID	OD	C/S	VOL(cm ³)
3	7	2.0	0.049	42	46	2.0	0.434
4	8	2.0	0.059	43	47	2.0	0.444
5	9	2.0	0.069	44	48	2.0	0.454
6	10	2.0	0.079	* 45	49	2.0	0.464
6.5	10.5	2.0	0.084	* 46	50	2.0	0.474
7	11	2.0	0.089	47	51	2.0	0.484
8	12	2.0	0.099	* 48	52	2.0	0.493
8.5	12.5	2.0	0.104	49	53	2.0	0.503
9	13	2.0	0.109	* 50	54	2.0	0.513
9.5	13.5	2.0	0.114	51	55	2.0	0.523
10	14	2.0	0.118	52	56	2.0	0.533
11	15	2.0	0.128	53	57	2.0	0.543
12	16	2.0	0.138	* 54	58	2.0	0.553
13	17	2.0	0.148	55	59	2.0	0.563
14	18	2.0	0.158	* 56	60	2.0	0.572
15	19	2.0	0.168	* 57	61	2.0	0.582
16	20	2.0	0.178	58	62	2.0	0.592
17	21	2.0	0.188	* 59	63	2.0	0.602
18	22	2.0	0.197	* 60	64	2.0	0.612
19	23	2.0	0.207	* 61	65	2.0	0.622
20	24	2.0	0.217	62	66	2.0	0.632
21	25	2.0	0.227	* 63	67	2.0	0.642
21.5	25.5	2.0	0.232	* 64	68	2.0	0.651
22	26	2.0	0.237	* 65	69	2.0	0.661
23	27	2.0	0.247	* 66	70	2.0	0.671
24	28	2.0	0.257	* 67	71	2.0	0.681
25	29	2.0	0.266	* 68	72	2.0	0.691
26	30	2.0	0.276	* 69	73	2.0	0.701
27	31	2.0	0.286	* 70	74	2.0	0.711
28	32	2.0	0.296	* 71	75	2.0	0.720
29	33	2.0	0.306	72	76	2.0	0.730
30	34	2.0	0.316	* 73	77	2.0	0.740
32	36	2.0	0.336	* 74	78	2.0	0.750
32.7	36.7	2.0	0.342	* 75	79	2.0	0.760
33	37	2.0	0.345	76	80	2.0	0.770
34	38	2.0	0.355	* 77	81	2.0	0.780
* 36	40	2.0	0.375	* 78	82	2.0	0.790
37	41	2.0	0.385	* 79	83	2.0	0.799
38	42	2.0	0.395	80	84	2.0	0.809
39	43	2.0	0.405	81	85	2.0	0.819
* 40	44	2.0	0.415	82	86	2.0	0.829
41	45	2.0	0.424	* 83	87	2.0	0.839

O-RING—2mm

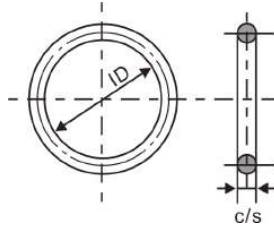

MATERIAL	
NBR	FKM
HNBR	SILICONE

ID	OD	C/S	VOL(cm ³)	ID	OD	C/S	VOL(cm ³)
* 84	88	2.0	0.849	* 100	104	2.0	1.007
* 85	89	2.0	0.859	105	109	2.0	1.056
* 86	90	2.0	0.869	* 107	111	2.0	1.076
* 87	91	2.0	0.878	* 110	114	2.0	1.105
* 88	92	2.0	0.888	* 112	116	2.0	1.125
* 89	93	2.0	0.898	* 114	118	2.0	1.145
90	94	2.0	0.908	* 115	119	2.0	1.155
* 91	95	2.0	0.918	* 118	122	2.0	1.184
* 92	96	2.0	0.928	* 120	124	2.0	1.204
92.5	96.5	2.0	0.933	* 122		2.0	1.224
* 93	97	2.0	0.938	* 125	129	2.0	1.253
* 94	98	2.0	0.947	* 128	132	2.0	1.283
* 95	99	2.0	0.957	* 130	134	2.0	1.303
* 96	100	2.0	0.967	* 135	139	2.0	1.352
* 97	101	2.0	0.977	* 140	144	2.0	1.401
* 98	102	2.0	0.987	* 145	149	2.0	1.451
* 99	103	2.0	0.997	* 150	154	2.0	1.500

PET SEALS

O-RING—2.5mm

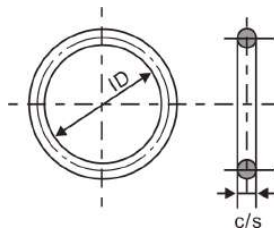

MATERIAL	
NBR	FKM
HNBR	SILICONE

ID	OD	C/S	VOL(cm ³)	ID	OD	C/S	VOL(cm ³)
5	10	2.5	0.116	32	37	2.5	0.532
7	12	2.5	0.147	33	38	2.5	0.547
8	13	2.5	0.162	* 37.2	42.2	2.5	0.612
8.7	13.7	2.5	0.173	38	43	2.5	0.625
9	14	2.5	0.177	43.3	48.3	2.5	0.706
9.7	14.7	2.5	0.188	44.5	49.5	2.5	0.725
10	15	2.5	0.193	49	54	2.5	0.794
11	16	2.5	0.208	50	55	2.5	0.810
11.6	16.6	2.5	0.217	52	57	2.5	0.840
12	17	2.5	0.224	55	60	2.5	0.887
12.5	17.5	2.5	0.231	57	62	2.5	0.918
12.6	17.6	2.5	0.233	58	63	2.5	0.933
13	18	2.5	0.239	60	65	2.5	0.964
13.5	18.5	2.5	0.247	61	66	2.5	0.979
14	19	2.5	0.254	65	70	2.5	1.041
14.6	19.6	2.5	0.264	70	75	2.5	1.118
15	20	2.5	0.270	70.5	75.5	2.5	1.126
16	21	2.5	0.285	73.5	78.5	2.5	1.172
17	22	2.5	0.301	75	80	2.5	1.195
17.5	22.5	2.5	0.308	80	85	2.5	1.272
18	23	2.5	0.316	85	90	2.5	1.349
18.5	23.5	2.5	0.324	90	95	2.5	1.426
19	24	2.5	0.332	93	98	2.5	1.473
20	25	2.5	0.347	95	100	2.5	1.504
21	26	2.5	0.362	100	105	2.5	1.581
22	27	2.5	0.378	105	110	2.5	1.658
23	28	2.5	0.393	110	115	2.5	1.735
23.5	28.5	2.5	0.401	115	120	2.5	1.812
* 24	29	2.5	0.409	120	125	2.5	1.889
25	30	2.5	0.424	125	130	2.5	1.966
26	31	2.5	0.440	127.5	132.5	2.5	2.005
27	32	2.5	0.455	130	135	2.5	2.043
27.5	32.5	2.5	0.463	135	140	2.5	2.120
29	34	2.5	0.486	140	145	2.5	2.198
* 30	35	2.5	0.501	155	160	2.5	2.429
31	36	2.5	0.517				

O-RING—3mm

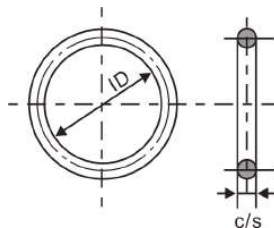

MATERIAL	
NBR	FKM
HNBR	SILICONE

ID	OD	C/S	VOL(cm ³)	ID	OD	C/S	VOL(cm ³)
3	9	3.0	0.133	* 39	45	3.0	0.933
4	10	3.0	0.155	* 40	46	3.0	0.955
4.5	10.5	3.0	0.167	41	47	3.0	0.977
5	11	3.0	0.178	42	48	3.0	0.999
5.5	11.5	3.0	0.189	* 43	49	3.0	1.022
6	12	3.0	0.200	44	50	3.0	1.044
6.5	12.5	3.0	0.211	* 45	51	3.0	1.066
7	13	3.0	0.222	46	52	3.0	1.088
8	14	3.0	0.244	47	53	3.0	1.110
9	15	3.0	0.266	48	54	3.0	1.133
10	16	3.0	0.289	49	55	3.0	1.155
11	17	3.0	0.311	50	56	3.0	1.177
12	18	3.0	0.333	* 51	57	3.0	1.199
13	19	3.0	0.355	52	58	3.0	1.221
14	20	3.0	0.378	* 53	59	3.0	1.244
15	21	3.0	0.400	54	60	3.0	1.266
16	22	3.0	0.422	* 55	61	3.0	1.288
17	23	3.0	0.444	56	62	3.0	1.310
18	24	3.0	0.466	57	63	3.0	1.332
18.5	24.5	3.0	0.477	58	64	3.0	1.355
19	25	3.0	0.489	* 59	65	3.0	1.377
20	26	3.0	0.511	* 60	66	3.0	1.399
21	27	3.0	0.533	* 61	67	3.0	1.421
22	28	3.0	0.555	62	68	3.0	1.443
23	29	3.0	0.577	* 63	69	3.0	1.466
23.5	29.5	3.0	0.588	* 64	70	3.0	1.488
24	30	3.0	0.600	65	71	3.0	1.510
24.2	30.2	3.0	0.604	* 66	72	3.0	1.532
25	31	3.0	0.622	* 67	73	3.0	1.554
26	32	3.0	0.644	* 68	74	3.0	1.577
27	33	3.0	0.666	69	75	3.0	1.599
28	34	3.0	0.688	70	76	3.0	1.621
29	35	3.0	0.711	* 71	77	3.0	1.643
30	36	3.0	0.733	72	78	3.0	1.666
31	37	3.0	0.755	* 73	79	3.0	1.688
32	38	3.0	0.777	* 74	80	3.0	1.710
33	39	3.0	0.799	* 75	81	3.0	1.732
34	40	3.0	0.822	* 76	82	3.0	1.754
35	41	3.0	0.844	77	83	3.0	1.777
36	42	3.0	0.866	78	84	3.0	1.799
37	43	3.0	0.888	* 79	85	3.0	1.821
38	44	3.0	0.910	* 80	86	3.0	1.843

O-RING—3mm

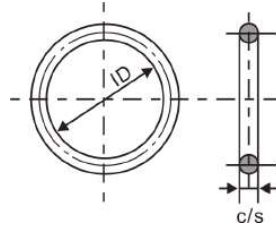

MATERIAL	
NBR	FKM
HNBR	SILICONE

ID	OD	C/S	VOL(cm ³)	ID	OD	C/S	VOL(cm ³)
* 81	87	3.0	1.865	* 132	138	3.0	2.998
82	88	3.0	1.888	* 133	139	3.0	3.020
* 83	89	3.0	1.910	* 134	140	3.0	3.042
* 84	90	3.0	1.932	* 135	141	3.0	3.065
* 85	91	3.0	1.954	* 138	144	3.0	3.131
* 86	92	3.0	1.976	* 139	145	3.0	3.153
* 87	93	3.0	1.999	* 140	146	3.0	3.176
* 88	94	3.0	2.021	* 145	151	3.0	3.287
* 89	95	3.0	2.043	* 146	152	3.0	3.309
* 90	96	3.0	2.065	* 148	154	3.0	3.353
* 91	97	3.0	2.087	150	156	3.0	3.398
* 92	98	3.0	2.110	* 155	161	3.0	3.509
* 93	99	3.0	2.132	* 160	166	3.0	3.620
* 94	100	3.0	2.154	* 162	168	3.0	3.664
* 95	101	3.0	2.176	* 165	171	3.0	3.731
* 96	102	3.0	2.198	* 166	172	3.0	3.753
* 97	103	3.0	2.221	170	176	3.0	3.842
98	104	3.0	2.243	* 173	179	3.0	3.908
* 99	105	3.0	2.265	* 174	180	3.0	3.931
100	106	3.0	2.287	* 175	181	3.0	3.953
* 101	107	3.0	2.309	* 178	184	3.0	4.019
* 102	108	3.0	2.332	* 180	186	3.0	4.064
* 103	109	3.0	2.354	* 185	191	3.0	4.175
* 104	110	3.0	2.376	* 189	195	3.0	4.264
* 105	111	3.0	2.398	* 190	196	3.0	4.286
* 106	112	3.0	2.421	* 195	201	3.0	4.397
* 107	113	3.0	2.443	* 200	206	3.0	4.508
108	114	3.0	2.465	* 205	211	3.0	4.619
* 109	115	3.0	2.487	209	215	3.0	4.708
110	116	3.0	2.509	210	216	3.0	4.730
* 112	118	3.0	2.554	* 215	221	3.0	4.841
* 113	119	3.0	2.576	* 220	226	3.0	4.952
* 114	120	3.0	2.598	* 225	231	3.0	5.063
* 115	121	3.0	2.620	* 230	236	3.0	5.174
* 117	123	3.0	2.665	232	238	3.0	5.219
* 120	126	3.0	2.731	* 235	241	3.0	5.285
* 122	128	3.0	2.776	* 240	246	3.0	5.396
* 124	130	3.0	2.820	* 245	251	3.0	5.507
125	131	3.0	2.842	* 250	256	3.0	5.618
* 126	132	3.0	2.865	* 255	261	3.0	5.729
* 128	134	3.0	2.909	* 260	266	3.0	5.840

O-RING—3mm

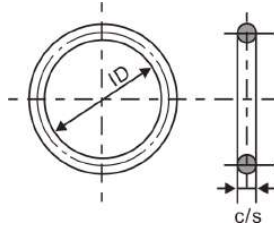

MATERIAL	
NBR	FKM
HNBR	SILICONE

ID	OD	C/S	VOL(cm ³)	ID	OD	C/S	VOL(cm ³)
* 130	136	3.0	2.953	265	271	3.0	5.951
* 270	276	3.0	6.062	* 295	301	3.0	6.618
* 275	281	3.0	6.173	* 300	306	3.0	6.729
* 280	286	3.0	6.284	* 310	316	3.0	6.951
285	291	3.0	6.396	325	331	3.0	7.284
* 290	296	3.0	6.507	* 330	336	3.0	7.395

PETSEALS

O-RING—3.5mm

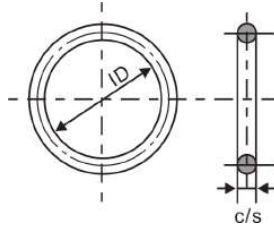

MATERIAL	
NBR	FKM
HNBR	SILICONE

ID	OD	C/S	VOL(cm ³)	ID	OD	C/S	VOL(cm ³)
8.5	15.5	3.5	0.363	97.6	104.6	3.5	3.056
* 16.7	23.7	3.5	0.611	104.6	111.6	3.5	3.267
19.7	26.7	3.5	0.701	109.6	116.6	3.5	3.419
31	38	3.5	1.043	114.6	121.6	3.5	3.570
33	40	3.5	1.103	119.6	126.6	3.5	3.721
51.6	58.6	3.5	1.665	129.6	136.6	3.5	4.023
* 54.6	61.6	3.5	1.756	134.6	141.6	3.5	4.174
* 57.6	64.6	3.5	1.847	144.6	151.6	3.5	4.476
61.6	68.6	3.5	1.968	174.6	181.6	3.5	5.383
64.6	71.6	3.5	2.058	180	187	3.5	5.546
* 67.6	74.6	3.5	2.149	260	267	3.5	7.964
69.6	76.6	3.5	2.210	274.6	281.6	3.5	8.406
* 71.6	78.6	3.5	2.270	350	357	3.5	10.685
* 77.6	84.6	3.5	2.451	* 359.6	366.6	3.5	10.975
81.6	88.6	3.5	2.572	370	377	3.5	11.289
87.6	94.6	3.5	2.754	390	397	3.5	11.894
91.6	98.6	3.5	2.874				

PET SEALS

O-RING—4mm / V

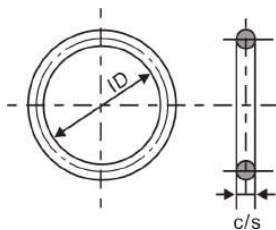

MATERIAL	
NBR	FKM
HNBR	SILICONE

ID	OD	C/S	VOL(cm³)	V系列	ID	OD	C/S	VOL(cm³)	V系列
8	16	4.0	0.474		46	54	4.0	1.974	
9	17	4.0	0.513		* 47	55	4.0	2.013	
10	18	4.0	0.553		48	56	4.0	2.053	
11	19	4.0	0.592		* 49	57	4.0	2.092	
12	20	4.0	0.632		50	58	4.0	2.132	
13	21	4.0	0.671		* 51	59	4.0	2.171	
14	22	4.0	0.711		52	60	4.0	2.211	
14.5	22.5	4.0	0.730	V	* 53	61	4.0	2.250	
15	23	4.0	0.750		54	62	4.0	2.290	
16	24	4.0	0.790		54.5	62.5	4.0	2.309	V
17	25	4.0	0.829		55	63	4.0	2.329	
18	26	4.0	0.869		56	64	4.0	2.369	
19	27	4.0	0.908		* 57	65	4.0	2.408	
20	28	4.0	0.947		* 58	66	4.0	2.448	
21	29	4.0	0.987		* 59	67	4.0	2.487	
22	30	4.0	1.026		60	68	4.0	2.527	
23	31	4.0	1.066		* 61	69	4.0	2.566	
23.5	31.5	4.0	1.086	V	62	70	4.0	2.606	
24	32	4.0	1.105		* 63	71	4.0	2.645	
25	33	4.0	1.145		* 64	72	4.0	2.685	
26	34	4.0	1.184		65	73	4.0	2.724	
27	35	4.0	1.224		* 66	74	4.0	2.764	
28	36	4.0	1.263		* 67	75	4.0	2.803	
29	37	4.0	1.303		* 68	76	4.0	2.842	
30	38	4.0	1.342		69	77	4.0	2.882	V
* 31	39	4.0	1.382		70	78	4.0	2.921	
32	40	4.0	1.421		* 71	79	4.0	2.961	
* 33	41	4.0	1.461		72	80	4.0	3.000	
33.5	41.5	4.0	1.480	V	* 73	81	4.0	3.040	
34	42	4.0	1.500		* 74	82	4.0	3.079	
35	43	4.0	1.540		75	83	4.0	3.119	
36	44	4.0	1.579		* 76	84	4.0	3.158	
* 37	45	4.0	1.619		* 77	85	4.0	3.198	
38	46	4.0	1.658		78	86	4.0	3.237	
* 39	47	4.0	1.698		* 79	87	4.0	3.277	
39.5	47.5	4.0	1.717	V	80	88	4.0	3.316	
40	48	4.0	1.737		* 81	89	4.0	3.356	
* 41	49	4.0	1.777		* 82	90	4.0	3.395	
42	50	4.0	1.816		83	91	4.0	3.435	
43	51	4.0	1.855		84	92	4.0	3.474	V
44	52	4.0	1.895		85	93	4.0	3.514	
45	53	4.0	1.934		* 86	94	4.0	3.553	

O-RING—4mm / V

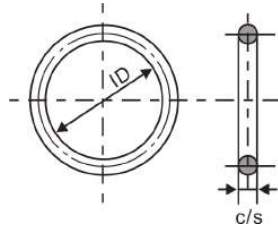

MATERIAL	
NBR	FKM
HNBR	SILICONE

ID	OD	C/S	VOL(cm³)	V系列	ID	OD	C/S	VOL(cm³)	V系列
* 87	95	4.0	3.593		130	138	4.0	5.290	
88	96	4.0	3.632		* 132	140	4.0	5.369	
* 89	97	4.0	3.672		* 134	142	4.0	5.448	
90	98	4.0	3.711		135	143	4.0	5.488	
* 91	99	4.0	3.750		140	148	4.0	5.685	
92	100	4.0	3.790		* 142	150	4.0	5.764	
93	101	4.0	3.829		* 144	152	4.0	5.843	
* 94	102	4.0	3.869		145	153	4.0	5.882	
95	103	4.0	3.908		148.5	156.5	4.0	6.020	V
* 96	104	4.0	3.948		150	158	4.0	6.080	
* 97	105	4.0	3.987		* 152	160	4.0	6.159	
98	106	4.0	4.027		155	163	4.0	6.277	
99	107	4.0	4.066	V	* 158	166	4.0	6.396	
100	108	4.0	4.106		160	168	4.0	6.474	
* 102	110	4.0	4.185		165	173	4.0	6.672	
104	112	4.0	4.264		170	178	4.0	6.869	
105	113	4.0	4.303		171.3	179.3	4.0	6.921	
* 106	114	4.0	4.343		172	180	4.0	6.948	
* 108	116	4.0	4.422		173	181	4.0	6.988	V
110	118	4.0	4.501		175	183	4.0	7.067	
112	120	4.0	4.580		180	188	4.0	7.264	
* 114	122	4.0	4.658		185	193	4.0	7.461	
115	123	4.0	4.698		190	198	4.0	7.659	
* 116	124	4.0	4.737		195	203	4.0	7.856	
* 117	125	4.0	4.777		200	208	4.0	8.054	
* 118	126	4.0	4.816		210	218	4.0	8.448	
119	127	4.0	4.856	V	* 220	228	4.0	8.843	
120	128	4.0	4.895		* 230	238	4.0	9.238	
* 122	130	4.0	4.974		* 232	240	4.0	9.317	
123	131	4.0	5.014		* 240	248	4.0	9.633	
* 124	132	4.0	5.053		* 250	258	4.0	10.028	
125	133	4.0	5.093		260	268	4.0	10.422	
* 126	134	4.0	5.132		348	356	4.0	13.896	
* 129	137	4.0	5.251		* 400	408	4.0	15.949	

O-RING—7mm

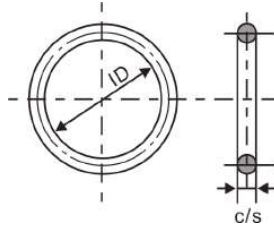

MATERIAL	
NBR	FKM
HNBR	SILICONE

ID	OD	C/S	VOL(cm ³)	ID	OD	C/S	VOL(cm ³)
244.1	258.08	7.0	30.271	104.2	118.2	7.0	13.444
274.1	288.08	7.0	33.888	107	121	7.0	13.783
287.41	301.39	7.0	35.492	108	122	7.0	13.904
57	71	7.0	7.738	112	126	7.0	14.387
62	76	7.0	8.342	147	161	7.0	18.619
67	81	7.0	8.947	167	181	7.0	21.037
67.7	81.7	7.0	9.031	208.92	222.92	7.0	26.105
72	86	7.0	9.551	215	229	7.0	26.841
77	91	7.0	10.156	574	588	7.0	70.245
82	96	7.0	10.760	615	629	7.0	75.202
83	97	7.0	10.881	625	639	7.0	76.411
87	101	7.0	11.365	650	664	7.0	79.433
92	106	7.0	11.969	705	719	7.0	86.083
94	108	7.0	12.211	724	738	7.0	88.380
97	111	7.0	12.574	740	754	7.0	90.315
98	112	7.0	12.695	760	774	7.0	92.733
102	116	7.0	13.178	880	894	7.0	107.241

PET SEALS

O-RING—4F

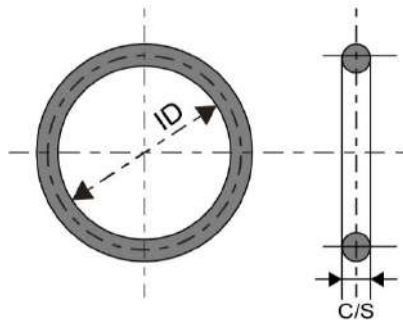

APPLICATION	
MATERIAL	PTFE
TEMP.	-55°C~200°C

ITEM	ID	C/S	VOL(cm ³)
4F-72	72	2	0.7304
4F-82	82	2	0.8291
4F-94	94	2	0.9475
2033	33.2	2.4	0.5060
2042	42.2	2.4	0.6339
AS-010	6.07	1.78	0.0614
AS-013	10.82	1.78	0.0399
AS-021	23.52	1.78	0.1978
AS-028	34.65	1.78	0.2848
AS-105	3.63	2.62	0.1059
AS-116	18.72	2.62	0.3614
AS-126	34.95	2.62	0.6363
AS-131	42.52	2.62	0.7646
AS-142	59.99	2.62	1.0604
AS-160	133.02	2.62	2.2974
AS-166	171.1	2.62	2.9423
AS-208	15.47	3.53	0.5842
AS-226	50.4	3.53	1.6581
AS-229	59.92	3.53	1.9508
AS-230	63.09	3.53	2.0483
AS-237	85.32	3.53	2.7318
AS-245	110.72	3.53	3.5128
AS-246	113.89	3.53	3.6102
AS-263	183.75	3.53	5.7581
AS-348	110.49	5.33	8.1186
AS-359	145.42	5.33	10.5670
AS-381	304.17	5.33	21.6949
AS-445	202.57	6.99	25.2641
AS-447	227.97	6.99	28.3263
AS-454	316.87	6.99	39.0439
AS-902	6.07	1.63	0.0505
G-140	139.8	3.1	3.3884
P-018	17.8	2.4	0.2871
P-050	49.7	3.5	1.6080

O-RING—POLYURETHANE O-RING

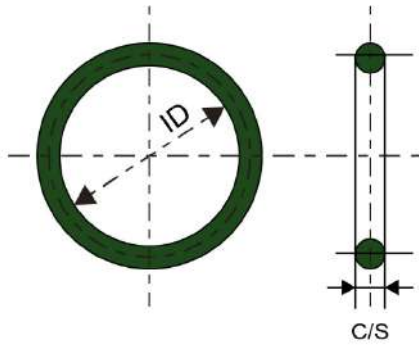

APPLICATION	
MATERIAL	POLYURETHANE
TEMP.	-40°C~100°C

ITEM	ID	C/S	COLOUR
P-016	15.8	2.4	GREEN
P-018	17.8	2.4	GREEN
P-021	20.8	2.4	IVORY
P-022A	21.7	3.5	GREEN
P-025	24.7	3.5	GREEN
P-026	25.7	3.5	IVORY
P-028	27.7	3.5	GREEN
P-030	29.7	3.5	GREEN
P-032	31.7	3.5	GREEN,IVORY
P-035	34.7	3.5	GREEN
P-035.5	35.2	3.5	GREEN
P-038	37.7	3.5	GREEN
P-045	44.7	3.5	GREEN
P-048	47.7	3.5	GREEN
P-070	69.6	5.7	GREEN
P-080	79.6	5.7	GREEN
P-085	84.6	5.7	GREEN
P-090	89.6	5.7	GREEN
P-100	99.6	5.7	GREEN
P-110	109.6	5.7	GREEN
P-115	114.6	5.7	GREEN
P-120	119.6	5.7	GREEN
P-125	124.6	5.7	GREEN
P-130	129.6	5.7	GREEN
P-135	134.6	5.7	GREEN
P-140	139.6	5.7	GREEN
P-150	149.6	5.7	GREEN
G-030	29.4	3.1	BLUE
G-035	34.4	3.1	GREEN
G-040	39.4	3.1	GREEN
G-045	44.4	3.1	IVORY
G-060	59.4	3.1	GREEN
G-066	65.4	3.1	IVORY
G-080	79.4	3.1	GREEN
G-085	84.4	3.1	GREEN
G-130	194.3	5.7	
G-195	194.3	5.7	BLACK
G-210	209.3	5.7	BLACK

O-RING—POLYURETHANE O-RING

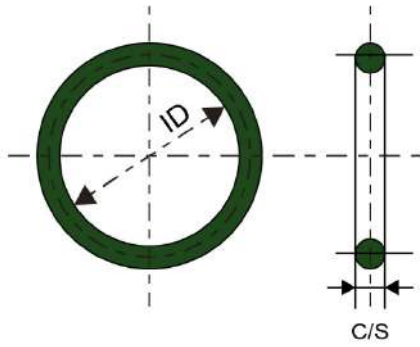

APPLICATION	
MATERIAL	POLYURETHANE
TEMP.	-40°C~100°C

ITEM	ID	C/S	COLOUR
AS-008	4.47	1.78	IVORY,GRAY
AS-009	5.28	1.78	IVORY,GRAY
AS-010	6.07	1.78	IVORY,GRAY
AS-016	15.6	1.78	IVORY
AS-120	25.07	2.62	IVORY
AS-213	23.39	3.53	IVORY
AS-230	63.10	3.53	IVORY
AS-333	62.87	5.33	IVORY
AS-345	100.96	5.33	IVORY
AS-347	107.32	5.33	IVORY
AS-348	110.49	5.33	IVORY
AS-350	116.84	5.33	IVORY
mm	14.5	2.5	BLUE
mm	75	3	IVORY
mm	53.4	3.8	IVORY
mm	47	5	GREEN
* mm	70	5	GREEN
mm	90	5	GREEN
mm	76	8	GREEN
mm	86	8	GREEN
mm	112	8	GREEN

SQUARE RING-AS-568 SERIES(SQ)

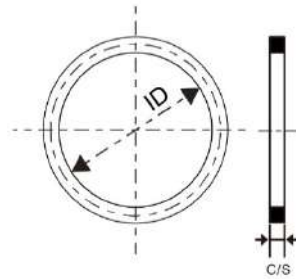

NBR

ITEM	ID	C/S
SQ-011	7.65	1.68
SQ-012	9.25	1.68
SQ-020	21.95	1.68
SQ-022	25.12	1.68
SQ-024	28.3	1.68
SQ-026	31.47	1.68
SQ-029	37.82	1.68
SQ-041	75.92	1.68
SQ-042	82.27	1.68
SQ-043	88.62	1.68
SQ-116	18.72	2.51
SQ-119	23.47	2.51
SQ-121	26.64	31.66
SQ-123	29.82	2.51
SQ-127	36.17	2.51
SQ-131	42.52	2.51
SQ-132	44.12	2.51
SQ-135	48.9	2.51
SQ-138	53.64	2.51
SQ-139	55.25	2.51
SQ-143	61.6	2.51
SQ-146	66.34	2.51
SQ-151	75.87	2.51
SQ-152	82.22	2.51
SQ-153	88.57	2.51
SQ-155	101.27	2.51
SQ-157	113.97	2.51
SQ-208	15.34	3.4
SQ-210	18.64	3.4
SQ-212	21.82	3.4
SQ-214	24.99	3.4
SQ-215	26.57	3.4
SQ-216	28.17	3.4
SQ-217	29.74	3.4
SQ-218	31.34	3.4

SQUARE RING-AS-568 SERIES(SQ)

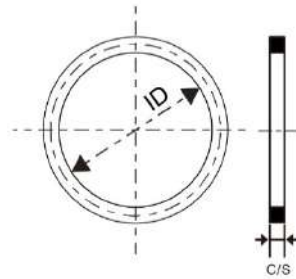

NBR

ITEM	ID	C/S
SQ-219	32.92	3.4
SQ-220	34.52	3.4
SQ-222	38.1	3.4
SQ-224	44.04	3.4
SQ-226	50.39	3.4
SQ-227	53.57	3.4
SQ-228	56.74	3.4
SQ-230	63.09	3.4
SQ-234	76.2	3.4
SQ-235	78.97	3.4
SQ-239	91.67	3.4
SQ-240	94.84	3.4
SQ-241	98.02	3.4
SQ-242	101.19	3.4
SQ-243	104.37	3.4
SQ-244	107.54	3.4
SQ-246	113.89	3.4
SQ-249	123.42	3.4
SQ-250	126.59	3.4
SQ-252	132.94	3.4
SQ-254	139.29	3.4
SQ-266	202.79	3.4
SQ-324	34.29	5.16
SQ-324	37.47	5.16
SQ-326	40.64	5.16
SQ-328	46.99	5.16
SQ-329	50.17	5.16
SQ-330	53.34	5.16
SQ-332	59.69	5.16
SQ-333	62.87	5.16
SQ-334	66.04	5.16
SQ-335	69.22	5.16
SQ-336	72.39	5.16
SQ-337	75.57	5.16
SQ-338	78.74	5.16

SQUARE RING-AS-568 SERIES(SQ)

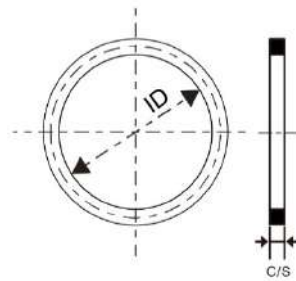

NBR

ITEM	ID	C/S
SQ-339	81.92	5.16
SQ-340	85.09	5.16
SQ-341	88.27	5.16
SQ-342	91.44	5.16
SQ-343	94.62	5.16
SQ-344	97.79	5.16
SQ-345	100.97	5.16
SQ-346	104.14	5.16
SQ-347	107.32	5.16
SQ-348	110.49	5.16
SQ-349	113.67	5.16
SQ-350	116.84	5.16
SQ-351	120.02	5.16
SQ-426	116.84	6.73
SQ-427	120.02	6.73
SQ-428	123.19	6.73
SQ-429	126.37	6.73
SQ-430	129.54	6.73
SQ-431	132.72	6.73
SQ-433	139.07	6.73
SQ-434	142.24	6.73
SQ-435	145.42	6.73
SQ-437	151.77	6.73
SQ-438	158.12	6.73
SQ-439	164.47	6.73
SQ-440	170.82	6.73
SQ-442	183.52	6.73
SQ-443	189.87	6.73

X-RING

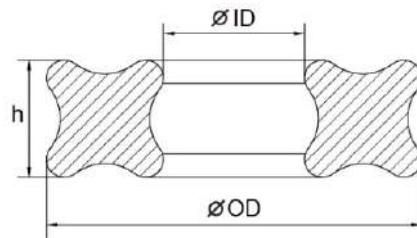

NBR70

ITEM	ID	C/S	VOL(cm ³)	ITEM	ID	C/S	VOL(cm ³)
* 001	0.74	1.02	0.005	* 043	88.62	1.78	0.707
* 002	1.07	1.27	0.009	* 044	94.97	1.78	0.756
* 003	1.42	1.53	0.017	* 045	101.32	1.78	0.806
* 004	1.78	1.78	0.028	* 046	107.62	1.78	0.855
* 005	2.57	1.78	0.034	* 047	114.02	1.78	0.905
* 006	2.90	1.78	0.037	* 048	120.37	1.78	0.955
* 007	3.69	1.78	0.043	* 049	126.72	1.78	1.005
* 008	4.47	1.78	0.049	* 050	133.07	1.78	1.054
* 009	5.29	1.78	0.055	* 102	1.24	2.62	0.065
* 010	6.07	1.78	0.061	* 103	2.05	2.62	0.079
* 011	7.65	1.78	0.074	* 104	2.84	2.62	0.092
* 012	9.25	1.78	0.086	* 105	3.63	2.62	0.106
013	10.82	1.78	0.099	* 106	4.42	2.62	0.119
014	12.42	1.78	0.111	* 107	5.23	2.62	0.133
* 015	14.00	1.78	0.123	* 108	6.02	2.62	0.146
016	15.60	1.78	0.136	* 109	7.60	2.62	0.173
* 017	17.17	1.78	0.148	* 110	9.19	2.62	0.200
018	18.77	1.78	0.161	* 111	10.77	2.62	0.227
019	20.35	1.78	0.173	* 112	12.37	2.62	0.254
* 020	21.95	1.78	0.186	113	13.95	2.62	0.281
* 021	23.52	1.78	0.198	114	15.54	2.62	0.308
* 022	25.12	1.78	0.210	115	17.12	2.62	0.334
023	26.70	1.78	0.223	116	18.72	2.62	0.361
* 024	28.30	1.78	0.235	117	20.29	2.62	0.388
* 025	29.87	1.78	0.247	* 118	21.90	2.62	0.415
* 026	31.47	1.78	0.260	* 119	23.47	2.62	0.442
027	33.05	1.78	0.272	* 120	25.07	2.62	0.469
028	34.65	1.78	0.285	121	26.65	2.62	0.496
* 029	37.82	1.78	0.310	* 122	28.25	2.62	0.523
030	41.00	1.78	0.334	* 123	29.82	2.62	0.549
* 031	44.17	1.78	0.359	124	31.42	2.62	0.577
032	47.35	1.78	0.384	125	32.99	2.62	0.603
033	50.52	1.78	0.409	126	34.60	2.62	0.630
034	53.70	1.78	0.434	* 127	36.17	2.62	0.657
* 035	56.87	1.78	0.459	128	37.77	2.62	0.684
036	60.04	1.78	0.483	* 129	39.35	2.62	0.711
* 037	63.22	1.78	0.508	* 130	40.95	2.62	0.738
* 038	66.40	1.78	0.533	131	42.52	2.62	0.765
* 039	69.57	1.78	0.558	* 132	44.12	2.62	0.792
* 040	72.75	1.78	0.583	133	45.70	2.62	0.818
* 041	75.92	1.78	0.607	134	47.30	2.62	0.846
* 042	82.27	1.78	0.657	* 135	48.90	2.62	0.873

X-RING

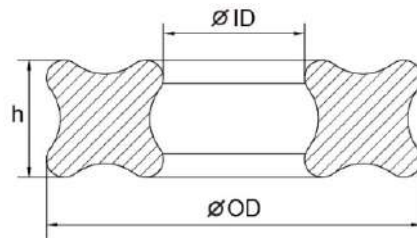

NBR70

ITEM	ID	C/S	VOL(cm ³)	ITEM	ID	C/S	VOL(cm ³)
* 136	50.47	2.62	0.899	* 178	247.3	2.62	4.233
137	52.07	2.62	0.926	* 201	4.34	3.53	0.242
* 138	53.65	2.62	0.953	* 202	5.94	3.53	0.291
139	55.25	2.62	0.980	* 203	7.52	3.53	0.340
140	56.82	2.62	1.007	* 204	9.12	3.53	0.389
141	58.40	2.62	1.034	* 205	10.69	3.53	0.437
* 142	60.00	2.62	1.061	* 206	12.29	3.53	0.486
* 143	61.00	2.62	1.078	207	13.87	3.53	0.535
144	63.10	2.62	1.113	208	15.47	3.53	0.584
145	64.70	2.62	1.140	209	17.04	3.53	0.632
* 146	66.30	2.62	1.167	210	18.64	3.53	0.682
147	67.90	2.62	1.194	211	20.22	3.53	0.730
* 148	69.50	2.62	1.222	212	21.82	3.53	0.779
149	71.10	2.62	1.249	* 213	23.40	3.53	0.828
150	72.70	2.62	1.276	214	24.99	3.53	0.877
151	75.87	2.62	1.329	215	26.57	3.53	0.925
152	82.22	2.62	1.437	216	28.17	3.53	0.975
153	88.57	2.62	1.545	* 217	29.75	3.53	1.023
154	94.92	2.62	1.652	218	31.34	3.53	1.072
155	101.2	2.62	1.758	219	32.92	3.53	1.121
156	107.6	2.62	1.867	220	34.52	3.53	1.170
157	113.9	2.62	1.974	* 221	36.10	3.53	1.218
158	120.3	2.62	2.082	222	37.70	3.53	1.268
* 159	126.6	2.62	2.189	223	40.87	3.53	1.365
160	133.0	2.62	2.297	* 224	44.05	3.53	1.463
161	139.3	2.62	2.404	225	47.22	3.53	1.560
162	145.7	2.62	2.512	* 226	50.40	3.53	1.658
* 163	152.0	2.62	2.619	227	53.57	3.53	1.756
164	158.7	2.62	2.732	228	56.75	3.53	1.853
165	164.7	2.62	2.834	229	59.92	3.53	1.951
166	171.1	2.62	2.942	230	63.10	3.53	2.049
* 167	177.4	2.62	3.049	231	66.27	3.53	2.146
168	183.8	2.62	3.157	232	69.44	3.53	2.244
* 169	190.1	2.62	3.264	233	72.62	3.53	2.341
170	196.5	2.62	3.373	* 234	75.79	3.53	2.439
* 171	202.8	2.62	3.479	235	78.97	3.53	2.537
* 172	209.2	2.62	3.588	236	82.14	3.53	2.634
* 173	215.5	2.62	3.694	237	85.32	3.53	2.732
* 174	221.9	2.62	3.803	238	88.49	3.53	2.829
* 175	228.6	2.62	3.916	239	91.67	3.53	2.927
* 176	234.6	2.62	4.018	240	94.84	3.53	3.025
* 177	240.9	2.62	4.125	241	98.02	3.53	3.122

X-RING

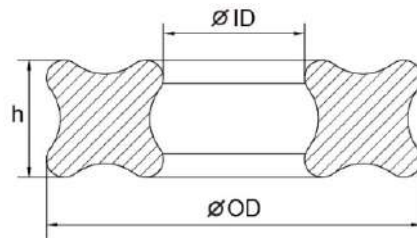

NBR70

ITEM	ID	C/S	VOL(cm ³)	ITEM	ID	C/S	VOL(cm ³)
242	101.20	3.53	3.220	* 284	456.06	3.53	14.131
243	104.37	3.53	3.318	* 309	10.46	5.33	1.107
244	107.54	3.53	3.415	* 310	12.07	5.33	1.220
* 245	110.72	3.53	3.513	* 311	13.64	5.33	1.330
246	113.89	3.53	3.610	* 312	15.24	5.33	1.442
247	117.05	3.53	3.707	* 313	16.81	5.33	1.552
248	120.24	3.53	3.805	* 314	18.42	5.33	1.665
* 249	123.42	3.53	3.903	315	19.99	5.33	1.775
250	126.59	3.53	4.001	* 316	21.59	5.33	1.887
* 251	129.77	3.53	4.098	* 317	23.16	5.33	1.997
252	132.94	3.53	4.196	* 318	24.77	5.33	2.110
253	136.12	3.53	4.294	* 319	26.34	5.33	2.220
254	139.3	3.53	4.391	* 320	27.94	5.33	2.332
* 255	142.47	3.53	4.489	* 321	29.51	5.33	2.442
256	145.65	3.53	4.587	* 322	31.12	5.33	2.555
* 257	148.82	3.53	4.684	* 323	32.69	5.33	2.665
* 258	152.00	3.53	4.782	* 324	34.29	5.33	2.777
* 259	158.35	3.53	4.977	325	37.47	5.33	3.000
* 260	164.70	3.53	5.172	326	40.65	5.33	3.223
261	171.05	3.53	5.368	* 327	43.82	5.33	3.445
* 262	177.40	3.53	5.563	* 328	46.99	5.33	3.667
* 263	183.75	3.53	5.758	* 329	50.16	5.33	3.890
* 264	190.10	3.53	5.953	* 330	53.34	5.33	4.113
* 265	196.45	3.53	6.149	331	56.52	5.33	4.335
* 266	202.80	3.53	6.344	332	59.69	5.33	4.558
267	209.15	3.53	6.539	* 333	62.87	5.33	4.781
* 268	215.50	3.53	6.734	334	66.04	5.33	5.003
269	221.85	3.53	6.930	335	69.22	5.33	5.226
* 270	228.20	3.53	7.125	336	72.39	5.33	5.448
* 271	234.55	3.53	7.320	337	75.6	5.33	5.673
* 272	240.90	3.53	7.515	* 338	78.74	5.33	5.893
* 273	247.25	3.53	7.711	339	81.92	5.33	6.116
* 274	253.60	3.53	7.906	340	85.09	5.33	6.338
275	266.30	3.53	8.296	341	88.27	5.33	6.561
* 276	279.00	3.53	8.687	342	91.44	5.33	6.783
* 277	291.70	3.53	9.077	343	94.62	5.33	7.006
* 278	304.40	3.53	9.468	344	97.79	5.33	7.228
* 279	329.80	3.53	10.249	345	100.96	5.33	7.451
* 280	355.20	3.53	11.030	346	104.14	5.33	7.673
* 281	380.60	3.53	11.811	347	107.35	5.33	7.898
* 282	405.26	3.53	12.569	348	110.49	5.33	8.119
* 283	430.66	3.53	13.350	349	113.67	5.33	8.341

X-RING

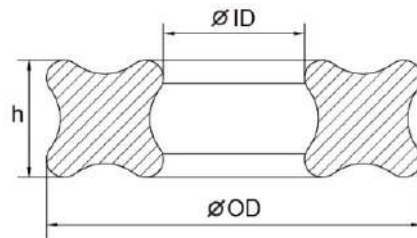

NBR70

ITEM	ID	C/S	VOL(cm ³)	ITEM	ID	C/S	VOL(cm ³)
350	116.84	5.33	8.564	* 392	582.65	5.33	41.215
351	120.02	5.33	8.787	* 393	608.10	5.33	42.999
* 352	123.19	5.33	9.009	* 394	633.50	5.33	44.780
* 353	126.37	5.33	9.232	* 395	658.85	5.33	46.557
* 354	129.54	5.33	9.454	425	113.67	6.99	14.547
* 355	132.72	5.33	9.677	* 426	116.84	6.99	14.929
* 356	135.89	5.33	9.899	* 427	120.02	6.99	15.312
* 357	139.07	5.33	10.122	* 428	123.19	6.99	15.694
* 358	142.24	5.33	10.344	* 429	126.37	6.99	16.078
* 359	145.42	5.33	10.567	430	129.54	6.99	16.460
* 360	148.59	5.33	10.789	* 431	132.72	6.99	16.843
* 361	151.77	5.33	11.012	* 432	135.89	6.99	17.225
* 362	158.12	5.33	11.457	* 433	139.07	6.99	17.609
* 363	164.47	5.33	11.902	* 434	142.24	6.99	17.991
* 364	170.82	5.33	12.347	435	145.42	6.99	18.374
* 365	177.17	5.33	12.793	* 436	148.59	6.99	18.756
* 366	183.52	5.33	13.238	437	151.77	6.99	19.140
* 367	189.87	5.33	13.683	438	158.12	6.99	19.905
* 368	196.22	5.33	14.128	439	164.47	6.99	20.671
* 369	202.57	5.33	14.573	* 440	170.82	6.99	21.436
* 370	208.92	5.33	15.018	* 441	177.17	6.99	22.202
* 371	215.27	5.33	15.463	* 442	183.52	6.99	22.968
* 372	221.62	5.33	15.908	* 443	189.00	6.99	23.628
* 373	227.97	5.33	16.354	* 444	196.22	6.99	24.499
* 374	234.32	5.33	16.799	* 445	202.57	6.99	25.264
* 375	240.67	5.33	17.244	* 446	215.27	6.99	26.795
* 376	247.02	5.33	17.689	* 447	227.97	6.99	28.326
* 377	253.37	5.33	18.134	* 448	240.67	6.99	29.857
* 378	266.07	5.33	19.024	* 449	253.37	6.99	31.388
* 379	278.77	5.33	19.914	* 450	266.07	6.99	32.920
* 380	291.47	5.33	20.805	* 451	278.77	6.99	34.451
* 381	304.17	5.33	21.695	* 452	291.47	6.99	35.982
* 382	329.55	5.33	23.474	* 453	304.17	6.99	37.513
* 383	354.97	5.33	25.256	* 454	316.87	6.99	39.044
* 384	380.37	5.33	27.036	* 455	329.57	6.99	40.575
* 385	405.26	5.33	28.781	* 456	342.27	6.99	42.106
* 386	430.65	5.33	30.561	* 457	354.97	6.99	43.637
* 387	456.06	5.33	32.342	* 458	367.67	6.99	45.168
* 388	481.46	5.33	34.122	* 459	380.37	6.99	46.699
* 389	506.86	5.33	35.903	* 460	393.03	6.99	48.226
* 390	532.26	5.33	37.683	* 461	405.26	6.99	49.700
* 391	557.66	5.33	39.464	* 462	417.96	6.99	51.231

X-RING

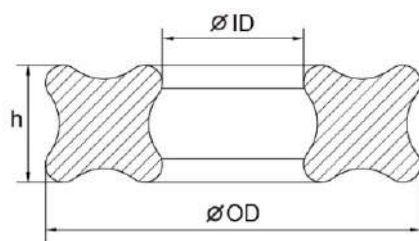

NBR70

ITEM	ID	C/S	VOL(cm ³)	ITEM	ID	C/S	VOL(cm ³)
* 463	430.66	6.99	52.762	* 470	532.26	6.99	65.011
* 464	443.36	6.99	54.293	* 471	557.66	6.99	68.073
* 465	456.06	6.99	55.824	* 472	582.65	6.99	71.086
* 466	468.76	6.99	57.355	* 473	608.10	6.99	74.154
* 467	481.46	6.99	58.887	* 474	633.50	6.99	77.216
* 468	494.16	6.99	60.418	* 475	658.85	6.99	80.272
* 469	506.86	6.99	61.949				

PETSEALS

HEAD SEAL- HI

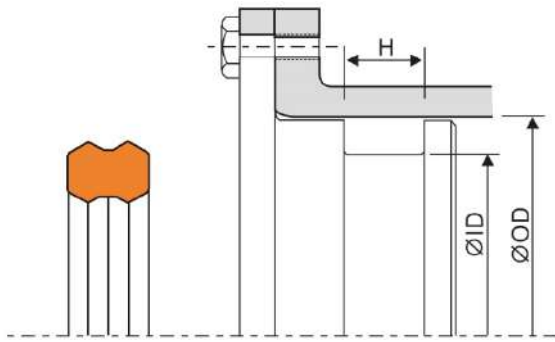

APPLICATION	
MATERIAL	PU
TEMP.	-40°F~212°F
PRESSURE	7000psi

ITEM	OD	ID	H
HI-039	2.875	2.738	0.138
HI-160	5.438	5.276	0.171
HI-218	1.500	1.278	0.208
HI-222	1.750	1.528	0.208
HI-224	2.000	1.778	0.208
HI-226	2.250	2.028	0.208
HI-227	2.375	2.153	0.208
HI-228	2.500	2.278	0.208
HI-230	2.750	2.528	0.208
HI-232	3.000	2.778	0.208
HI-234	3.250	3.028	0.208
HI-235	3.375	3.153	0.208
HI-236	3.500	3.278	0.208
HI-237	3.625	3.403	0.208
HI-238	3.750	3.528	0.208
HI-239	3.875	3.653	0.208
HI-240	4.000	3.778	0.208
HI-241	4.125	3.903	0.208
HI-242	4.250	4.028	0.208
HI-243	4.375	4.153	0.208
HI-244	4.500	4.278	0.208
HI-245	4.625	4.403	0.208
HI-246	4.750	4.528	0.208
HI-247	4.875	4.653	0.208
HI-248	5.000	4.778	0.208
HI-249	5.125	4.903	0.208
HI-250	5.250	5.028	0.208
HI-251	5.375	5.153	0.208
HI-252	5.500	5.278	0.208
HI-253	5.625	5.403	0.208
HI-254	5.750	5.528	0.208
HI-255	5.875	5.653	0.208
HI-256	6.000	5.778	0.208
HI-257	6.125	5.903	0.208
HI-258	6.250	6.028	0.208
HI-259	6.500	6.278	0.208
HI-260	6.750	6.528	0.208
HI-261	7.000	6.778	0.208
HI-262	7.250	7.028	0.208

HEAD SEAL- HI

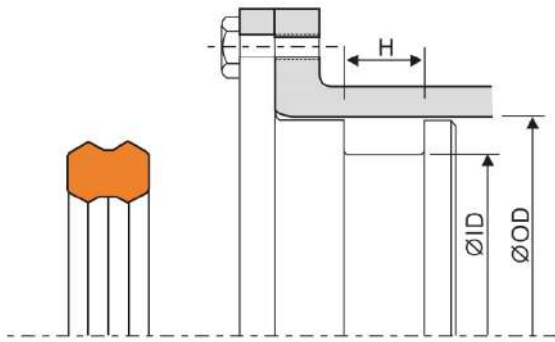

APPLICATION	
MATERIAL	PU
TEMP.	-40°F~212°F
PRESSURE	7000psi

ITEM	OD	ID	H
HI-263	7.500	7.278	0.208
HI-265	8.000	7.778	0.208
HI-338	3.500	3.160	0.311
HI-342	4.000	3.660	0.311
HI-343	4.125	3.785	0.299
HI-344	4.250	3.910	0.311
HI-346	4.500	4.160	0.311
HI-347	4.625	4.285	0.311
HI-348	4.750	4.410	0.311
HI-350	5.000	4.660	0.311
HI-352	5.250	4.910	0.311
HI-353	5.375	5.035	0.311
HI-354	5.500	5.160	0.311
HI-356	5.750	5.410	0.311
HI-358	6.000	5.660	0.311
HI-360	6.250	5.910	0.311

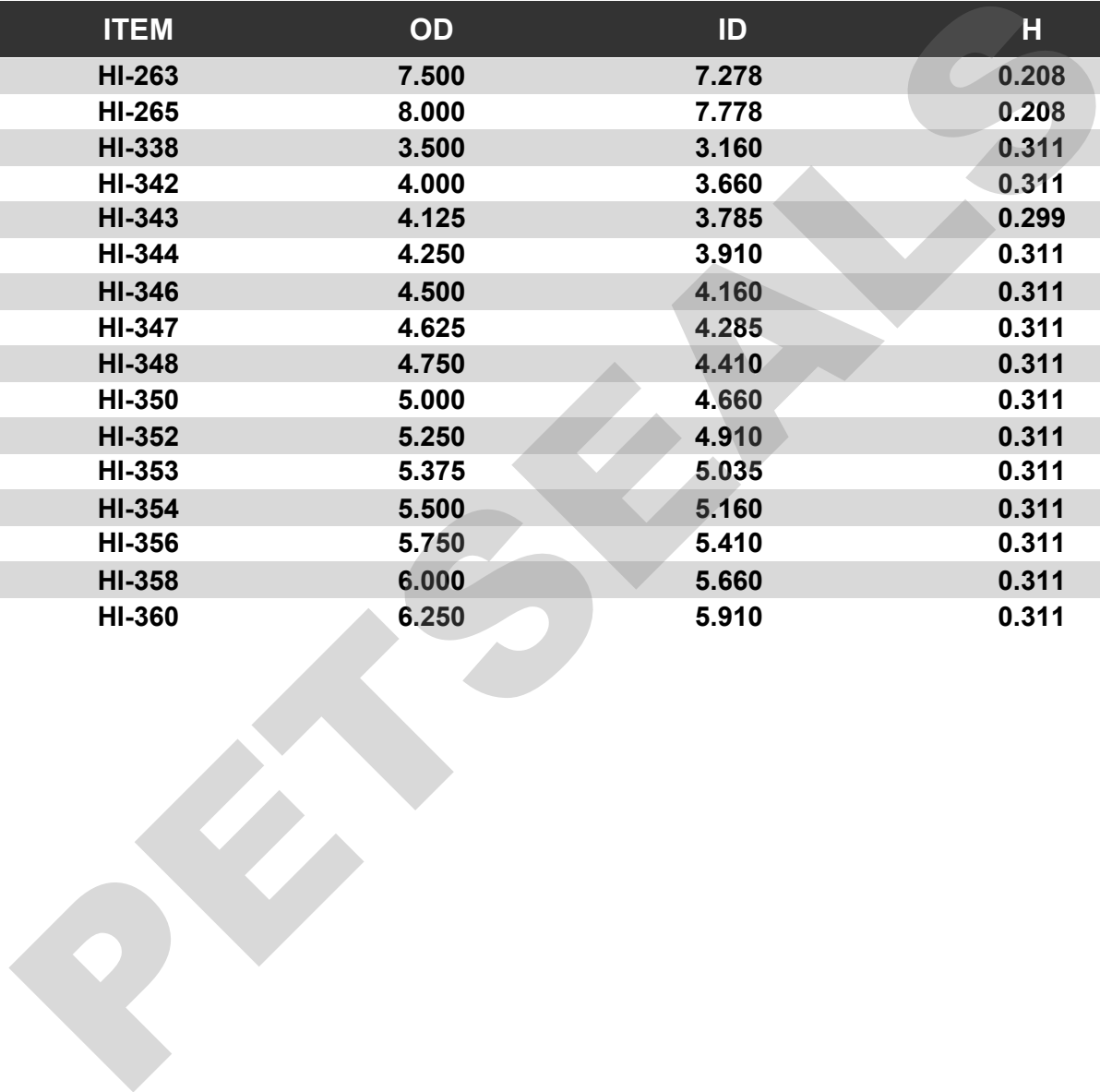

FLANGE STATIC SEAL

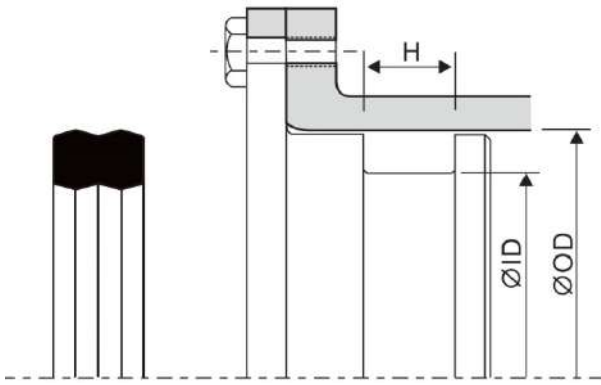

APPLICATION	
MATERIAL	NBR
TEMP.	-40°F~212°F
PRESSURE	7000psi

ITEM	OD	ID	H
HI-N224	2.000	1.734	0.175
HI-N228	2.500	2.233	0.175
HI-N232	3.000	2.778	0.175
HI-N236	3.500	3.278	0.175
HI-N240	4.000	3.778	0.175

PETSEALS

ED seals according to DIN 3869

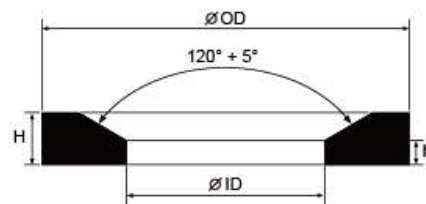
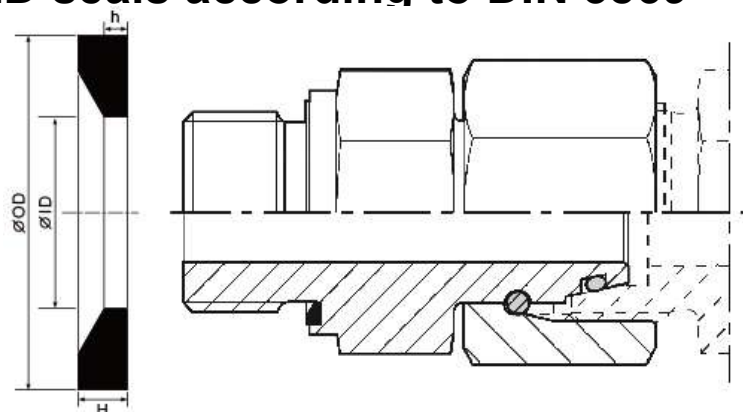

APPLICATION	
MATERIAL	NBR
TEMP.	-30°C~100°C

Total 300pcs, 15 sizes x 20 pcs each

ITEM	Thread configuration		OD	ID	H ± 0.1	h + 0.2
	METRIC	INCHES				
ED-8	M8x1		9.9	6.5	1.0	0.5
ED-10	M10x1	G1/8A	11.9	8.4	1.0	0.5
ED-12	M12x1.5		14.4	9.8	1.5	0.8
ED-14	M14x1.5	G1/4A	16.5	11.6	1.5	0.8
ED-16	M16x1.5		18.9	13.8	1.5	0.8
ED-17	M17x1.5	G3/8A	18.9	14.7	1.5	0.8
ED-18	M18x1.5		20.9	15.7	1.5	0.8
ED-20	M20x1.5		22.9	17.8	1.5	0.8
ED-21	M21x1.5	G1/2A	23.9	18.5	1.5	0.8
ED-22	M22x1.5		24.3	19.6	1.5	0.8
ED-24	M24*1.5		26.9	21.8	1.5	0.8
ED-26	M26x1.5	G3/4A	29.2	23.9	1.5	0.8
* ED-27	M27x2	G3/4A	29.2	23.9	1.5	0.8
* ED-30	M30x2		32.7	26.7	2.0	1.0
ED-33	M33x2	G1A	35.7	29.7	2.0	1.0
* ED-36	M36x2		38.7	32.7	2.0	1.0
* ED-39	M39x2		41.7	35.7	2.0	1.0
ED-42	M42x2	G1 1/4A	45.8	38.8	2.0	1.0
ED-48	M48x2	G1 1/2A	50.7	44.7	2.0	1.0
* ED-50	M50x2	G1 3/4A	56.7	50.4	2.5	1.25
* ED-60	M60x2	G2A	62.7	56.1	2.5	1.25

WD CAPTIVE SEALS FOR THREADED CONNECTORS

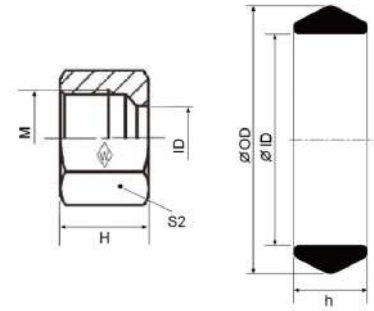

APPLICATION	
MATERIAL	FKM
TEMP.	-20°C~200°C

WD SEAL KIT, INCLUDING 10 SIZES X 20 PCS EACH. TOTAL 200 PCS.

Series	Bar (psi)	ITEM	Type	For Thread	H	h
L	500 (7252)	WD-08	M 8L	M 14*1.5	8L/S	2.7
		WD-10	M 10L	M 16*1.5	10L/S	3
	400 (5801)	WD-12	M 12L	M 18*1.5	12L/S	3
		WD-15	M 15L	M 22*1.5	15L	3
	250 (3626)	WD-35	M 35L	M 45*2	35L	3.5
		WD-42	M 42L	M 52*2	42L	3.5
S	800 (11603)	WD-08	M 8S	M 16*1.5	8L/S	2.7
		WD-10	M 10S	M 18*1.5	10L/S	3
		WD-12	M 12S	M 20*1.5	12L/S	3
	630 (9137)	WD-16	M 16S	M 24*1.5	16S	2.95
		420 (6091)	WD-20	M 20S	M 30*2	20S
	WD-25		M 25S	M 36*2	25S	3.7
	WD-30		M 30S	M 42*2	30S	3.85

BACKUP RING—AS-568 SERIES

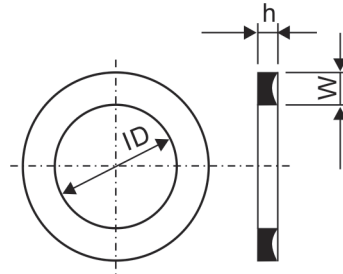

NBR90

ITEM	ID	W	h	ITEM	ID	W	h
* 004	2.44	1.35	1.24	* 045	102.06	1.35	1.24
* 005	3.23	1.35	1.24	* 046	108.41	1.35	1.24
* 006	3.56	1.35	1.24	* 047	114.76	1.35	1.24
* 007	4.34	1.35	1.24	* 048	121.11	1.35	1.24
008	5.13	1.35	1.24	* 049	127.46	1.35	1.24
* 009	5.94	1.35	1.24	* 050	133.81	1.35	1.24
* 010	6.73	1.35	1.24	* 102	1.96	2.18	1.35
* 011	8.31	1.35	1.24	* 103	2.77	2.18	1.35
012	9.91	1.35	1.24	* 104	3.56	2.18	1.35
* 013	11.56	1.35	1.24	* 105	4.34	2.18	1.35
014	13.16	1.35	1.24	* 106	5.13	2.18	1.35
015	14.73	1.35	1.24	* 107	5.91	2.18	1.35
016	16.33	1.35	1.24	* 108	6.73	2.18	1.35
017	17.91	1.35	1.24	* 109	8.31	2.18	1.35
018	19.51	1.35	1.24	110	9.91	2.18	1.35
* 019	21.08	1.35	1.24	* 111	11.48	2.18	1.35
020	22.68	1.35	1.24	* 112	13.08	2.18	1.35
021	24.26	1.35	1.24	* 113	14.66	2.18	1.35
* 022	25.86	1.35	1.24	* 114	16.26	2.18	1.35
* 023	27.43	1.35	1.24	115	17.83	2.18	1.35
* 024	29.03	1.35	1.24	* 116	19.43	2.18	1.35
025	30.61	1.35	1.24	117	21.11	2.18	1.35
026	32.21	1.35	1.24	* 118	22.68	2.18	1.35
027	33.78	1.35	1.24	* 119	24.28	2.18	1.35
* 028	35.38	1.35	1.24	120	25.86	2.18	1.35
* 029	38.56	1.35	1.24	121	27.46	2.18	1.35
* 030	41.73	1.35	1.24	* 122	29.03	2.18	1.35
* 031	44.91	1.35	1.24	123	30.63	2.18	1.35
* 032	48.08	1.35	1.24	124	32.21	2.18	1.35
* 033	51.26	1.35	1.24	125	33.81	2.18	1.35
* 034	54.43	1.35	1.24	126	35.38	2.18	1.35
* 035	57.61	1.35	1.24	127	36.98	2.18	1.35
* 036	60.78	1.35	1.24	128	38.56	2.18	1.35
* 037	63.96	1.35	1.24	* 129	40.16	2.18	1.35
* 038	67.13	1.35	1.24	130	41.73	2.18	1.35
* 039	70.31	1.35	1.24	131	43.33	2.18	1.35
* 040	73.48	1.35	1.24	132	44.91	2.18	1.35
* 041	76.66	1.35	1.24	133	46.51	2.18	1.35
* 042	83.01	1.35	1.24	134	48.08	2.18	1.35
* 043	89.36	1.35	1.24	* 135	49.68	2.18	1.35
* 044	95.71	1.35	1.24	* 136	51.26	2.18	1.35

BACKUP RING—AS-568 SERIES

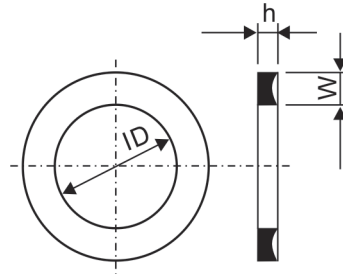

NBR90

ITEM	ID	W	h	ITEM	ID	W	h
* 137	52.86	2.18	1.35	* 178	248.11	2.18	1.35
* 138	54.43	2.18	1.35	* 201	5.13	3	1.27
* 139	56.03	2.18	1.35	* 202	6.73	3	1.27
140	57.61	2.18	1.35	* 203	8.31	3	1.27
* 141	59.21	2.18	1.35	* 204	9.91	3	1.27
* 142	60.78	2.18	1.35	* 205	11.56	3	1.27
* 143	62.38	2.18	1.35	* 206	13.16	3	1.27
* 144	63.96	2.18	1.35	207	14.73	3	1.27
* 145	65.56	2.18	1.35	* 208	16.33	3	1.27
* 146	67.13	2.18	1.35	* 209	17.91	3	1.27
* 147	68.73	2.18	1.35	* 210	19.46	3	1.27
* 148	70.31	2.18	1.35	211	21.03	3	1.27
* 149	71.91	2.18	1.35	* 212	22.63	3	1.27
* 150	73.48	2.18	1.35	* 213	24.21	3	1.27
* 151	76.66	2.18	1.35	* 214	25.81	3	1.27
* 152	83.01	2.18	1.35	* 215	27.38	3	1.27
* 153	89.36	2.18	1.35	* 216	28.98	3	1.27
* 154	95.71	2.18	1.35	* 217	30.56	3	1.27
* 155	102.06	2.18	1.35	218	32.16	3	1.27
* 156	108.41	2.18	1.35	* 219	33.88	3	1.27
* 157	114.76	2.18	1.35	* 220	35.48	3	1.27
* 158	121.11	2.18	1.35	* 221	37.06	3	1.27
* 159	127.46	2.18	1.35	* 222	38.66	3	1.27
* 160	133.81	2.18	1.35	* 223	41.83	3	1.27
* 161	140.16	2.18	1.35	224	45.01	3	1.27
* 162	146.51	2.18	1.35	* 225	48.18	3	1.27
* 163	152.86	2.18	1.35	* 226	51.36	3	1.27
* 164	159.21	2.18	1.35	* 227	54.53	3	1.27
* 165	165.56	2.18	1.35	228	57.71	3	1.27
* 166	171.91	2.18	1.35	229	60.88	3	1.27
* 167	178.26	2.18	1.35	* 230	64.06	3	1.27
* 168	184.61	2.18	1.35	* 231	66.83	3	1.27
* 169	190.96	2.18	1.35	232	70.00	3	1.27
* 170	197.31	2.18	1.35	* 233	73.18	3	1.27
* 171	203.66	2.18	1.35	234	76.35	3	1.27
* 172	210.01	2.18	1.35	* 235	79.53	3	1.27
* 173	216.36	2.18	1.35	236	82.70	3	1.27
* 174	222.71	2.18	1.35	* 237	85.88	3	1.27
* 175	229.06	2.18	1.35	* 238	89.05	3	1.27
* 176	235.41	2.18	1.35	* 239	92.23	3	1.27
* 177	241.76	2.18	1.35	240	95.40	3	1.27

BACKUP RING—AS-568 SERIES

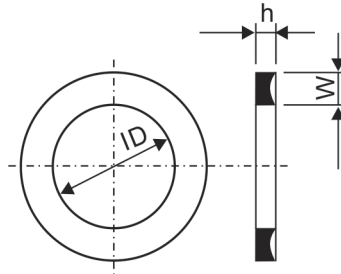

NBR90

ITEM	ID	W	h	ITEM	ID	W	h
* 241	98.58	3	1.27	* 282	406.12	3	1.27
* 242	101.75	3	1.27	* 283	431.52	3	1.27
* 243	104.93	3	1.27	* 284	456.92	3	1.27
* 244	108.10	3	1.27	* 309	11.43	4.65	1.93
* 245	111.28	3	1.27	* 310	13.03	4.65	1.93
246	114.45	3	1.27	* 311	14.61	4.65	1.93
* 247	117.63	3	1.27	* 312	16.21	4.65	1.93
* 248	121.11	3	1.27	* 313	17.78	4.65	1.93
* 249	124.28	3	1.27	* 314	19.38	4.65	1.93
250	127.46	3	1.27	* 315	20.96	4.65	1.93
* 251	130.63	3	1.27	* 316	22.56	4.65	1.93
252	133.81	3	1.27	* 317	24.13	4.65	1.93
* 253	136.98	3	1.27	* 318	25.74	4.65	1.93
* 254	140.16	3	1.27	* 319	27.31	4.65	1.93
* 255	143.33	3	1.27	* 320	28.91	4.65	1.93
* 256	146.51	3	1.27	* 321	30.42	4.65	1.93
* 257	149.68	3	1.27	* 322	32.08	4.65	1.93
* 258	152.86	3	1.27	* 323	33.43	4.65	1.93
* 259	159.21	3	1.27	* 324	35.26	4.65	1.93
* 260	165.56	3	1.27	* 325	38.43	4.65	1.93
261	171.91	3	1.27	* 326	41.61	4.65	1.93
262	178.26	3	1.27	* 327	44.78	4.65	1.93
* 263	184.61	3	1.27	* 328	47.96	4.65	1.93
* 264	190.96	3	1.27	* 329	51.13	4.65	1.93
* 265	197.31	3	1.27	* 330	54.31	4.65	1.93
* 266	203.66	3	1.27	* 331	57.61	4.65	1.93
* 267	210.01	3	1.27	* 332	60.78	4.65	1.93
* 268	216.36	3	1.27	* 333	63.96	4.65	1.93
* 269	222.71	3	1.27	* 334	67.13	4.65	1.93
* 270	229.06	3	1.27	* 335	70.31	4.65	1.93
* 271	235.41	3	1.27	* 336	73.48	4.65	1.93
* 272	241.76	3	1.27	* 337	76.66	4.65	1.93
* 273	248.11	3	1.27	338	79.83	4.65	1.93
* 274	254.46	3	1.27	* 339	83.13	4.65	1.93
* 275	267.16	3	1.27	* 340	86.31	4.65	1.93
* 276	279.86	3	1.27	* 341	89.48	4.65	1.93
* 277	292.56	3	1.27	* 342	92.66	4.65	1.93
* 278	305.26	3	1.27	* 343	95.83	4.65	1.93
* 279	330.66	3	1.27	* 344	99.01	4.65	1.93
* 280	356.06	3	1.27	* 345	102.31	4.65	1.93
* 281	381.46	3	1.27	* 346	105.49	4.65	1.93

BACKUP RING—AS-568 SERIES

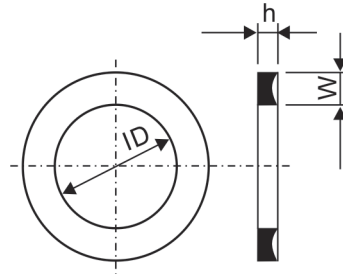

NBR90

ITEM	ID	W	h	ITEM	ID	W	h
* 347	108.66	4.65	1.93	* 359	146.76	4.65	1.93
* 348	111.84	4.65	1.93	* 360	149.94	4.65	1.93
* 349	115.01	4.65	1.93	* 361	153.11	4.65	1.93
350	118.19	4.65	1.93	* 362	159.46	4.65	1.93
* 351	121.36	4.65	1.93	363	165.81	4.65	1.93
* 352	124.54	4.65	1.93	* 364	172.16	4.65	1.93
* 353	127.71	4.65	1.93	* 365	178.51	4.65	1.93
* 354	130.89	4.65	1.93	* 366	184.86	4.65	1.93
* 355	134.06	4.65	1.93	* 434	144.17	5.99	2.97
* 356	137.24	4.65	1.93	* 435	147.35	5.99	2.97
* 357	140.41	4.65	1.93	* 436	150.52	5.99	2.97
* 367	191.21	4.65	1.93	437	153.70	5.99	2.97
* 368	197.56	4.65	1.93	* 438	159.36	5.99	2.97
369	203.91	4.65	1.93	* 439	165.71	5.99	2.97
* 370	210.26	4.65	1.93	* 440	172.06	5.99	2.97
* 371	216.61	4.65	1.93	* 441	178.41	5.99	2.97
* 372	222.96	4.65	1.93	* 442	184.76	5.99	2.97
* 373	229.31	4.65	1.93	* 443	191.11	5.99	2.97
* 374	235.66	4.65	1.93	* 444	197.46	5.99	2.97
* 375	242.01	4.65	1.93	* 445	203.81	5.99	2.97
* 376	248.36	4.65	1.93	* 446	216.51	5.99	2.97
* 377	254.71	4.65	1.93	* 447	229.21	5.99	2.97
* 378	267.41	4.65	1.93	448	241.91	5.99	2.97
* 379	280.11	4.65	1.93	* 449	254.61	5.99	2.97
* 380	292.81	4.65	1.93	* 450	267.31	5.99	2.97
* 381	305.51	4.65	1.93	* 451	280.01	5.99	2.97
* 382	330.91	4.65	1.93	* 452	292.71	5.99	2.97
* 383	356.31	4.65	1.93	* 453	305.41	5.99	2.97
* 384	381.71	4.65	1.93	* 454	318.11	5.99	2.97
* 385	406.60	4.65	1.93	* 425	115.60	5.99	2.97
* 386	432.00	4.65	1.93	* 426	118.77	5.99	2.97
* 387	457.40	4.65	1.93	* 427	121.95	5.99	2.97
* 388	482.75	4.65	1.93	* 428	125.12	5.99	2.97
* 389	508.15	4.65	1.93	* 429	128.30	5.99	2.97
* 390	533.55	4.65	1.93	* 430	131.47	5.99	2.97
* 391	558.95	4.65	1.93	* 431	134.65	5.99	2.97
* 392	584.02	4.65	1.93	* 432	137.82	5.99	2.97
* 393	609.42	4.65	1.93	* 433	141.00	5.99	2.97
* 394	634.82	4.65	1.93	* 455	330.81	5.99	2.97
* 395	660.22	4.65	1.93	* 456	343.51	5.99	2.97
* 358	143.59	4.65	1.93	* 457	356.21	5.99	2.97

BACKUP RING—AS-568 SERIES

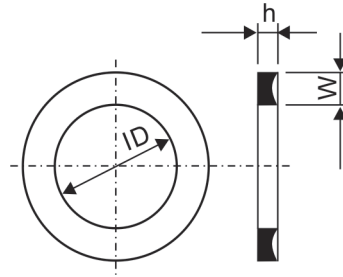

NBR90

ITEM	ID	W	h	ITEM	ID	W	h
* 458	368.91	5.99	2.97	* 467	482.70	5.99	2.97
* 459	381.61	5.99	2.97	* 468	495.40	5.99	2.97
* 460	394.31	5.99	2.97	* 469	508.10	5.99	2.97
* 461	406.50	5.99	2.97	* 470	533.50	5.99	2.97
* 462	419.20	5.99	2.97	* 471	558.90	5.99	2.97
* 463	431.90	5.99	2.97	* 472	584.30	5.99	2.97
* 464	444.60	5.99	2.97	* 473	609.70	5.99	2.97
* 465	457.30	5.99	2.97	* 474	635.10	5.99	2.97
* 466	470.00	5.99	2.97	* 475	660.50	5.99	2.97

PETSEALS

BACKUP RING—AS-568 SERIES

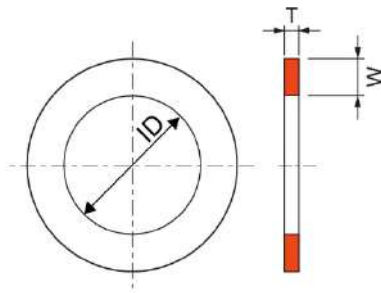

APPLICATION	
MATERIAL	HYTREL
TEMP.	-55°C~100°C

ITEM	ID	OD	h	ITEM	ID	OD	h
* 8	5.371	7.809	1.14	111	11.48	15.84	1.14
* 9	6.157	8.595	1.14	* 111A	11.731	15.745	1.25
* 10	6.968	9.406	1.14	* 112	13.302	17.316	1.25
11	8.31	11.01	1.14	* 113	14.898	18.912	1.25
* 12	10.135	12.573	1.14	114	16.26	20.62	1.25
12A	9.91	12.61	1.24	115	17.83	22.03	1.25
13A	11.705	14.143	0.71	* 115A	18.065	22.079	1.25
13	11.705	14.143	1.14	116	19.43	23.79	1.25
14	13.16	15.86	1.14	117	21.11	25.31	1.25
15	14.73	17.43	1.14	117A	21.232	25.246	1.25
16	16.469	18.907	1.14	* 118	22.803	26.817	1.25
17	18.04	20.478	1.14	* 119	24.399	28.413	1.25
18	19.636	22.074	1.14	* 120	25.97	29.984	1.25
18A	19.51	22.21	1.24	121	27.566	31.58	1.25
19	21.207	23.645	1.14	* 122	29.137	33.151	1.25
19A	21.08	23.78	1.24	* 123	30.733	34.747	1.25
* 20	22.803	25.251	1.14	124	32.304	36.318	1.25
20A	22.48	25.08	1.24	125	33.9	37.914	1.25
21	24.374	26.812	1.14	126	35.471	39.485	1.25
22	25.65	28.25	1.14	127	37.067	41.081	1.25
* 22	25.970	28.408	1.14	128	38.56	42.92	1.25
* 23	27.541	29.979	1.14	129	40.234	44.248	1.25
* 24	29.137	31.575	1.14	* 130	41.805	45.819	1.25
* 25	30.708	33.146	1.14	131	43.401	47.415	1.25
* 26	32.304	34.742	1.14	* 132	44.972	48.986	1.25
26A	32.21	34.81	1.24	133	46.51	50.87	1.25
* 27	33.875	36.313	1.14	134	48.139	52.153	1.25
* 28	35.471	37.909	1.14	135	49.68	53.64	1.25
29	38.56	41.25	1.14	136	51.26	55.62	1.25
30	41.53	44.07	1.14	137	52.86	56.82	1.25
* 30	41.805	44.243	1.14	* 137	52.903	56.917	1.25
* 31	44.972	47.41	1.14	140	57.641	61.655	1.25
* 32	48.139	50.577	1.14	* 141	59.237	63.251	1.25
* 33	51.306	53.744	1.14	142	60.78	65.14	1.25
* 34	54.473	56.911	1.14	* 143	62.404	66.418	1.25
* 35	57.641	60.079	1.14	* 144	63.98	67.994	1.25
* 36	60.808	63.246	1.14	* 145	65.571	69.585	1.25
* 40	73.476	75.914	1.14	* 146	67.142	71.156	1.25
* 43	89.311	91.749	1.14	147	68.73	72.69	1.25
* 110	10.135	14.149	1.25	* 148	70.309	74.323	1.25

BACKUP RING—AS-568 SERIES

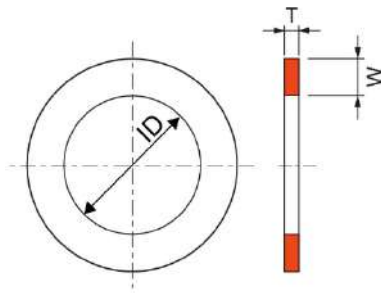

APPLICATION	
MATERIAL	HYTREL
TEMP.	-55°C~100°C

ITEM	ID	OD	h	ITEM	ID	OD	h
149	71.91	76.11	1.25	238	89.387	94.925	1.25
150	73.48	77.68	1.25	239	92.554	98.092	1.25
* 152	82.977	86.991	1.25	240	95.721	101.259	1.25
* 153	89.311	93.325	1.25	241	98.58	104.58	1.25
* 154	95.645	99.659	1.25	242	102.055	107.593	1.25
* 155	101.979	105.993	1.25	243	104.93	110.93	1.25
* 159	127.316	131.33	1.25	244	108.46	113.94	1.25
* 160	133.65	137.664	1.25	245	111.557	117.095	1.25
* 163	152.652	156.666	1.25	246	114.724	120.262	1.25
206	13.13	19.13	1.25	247	117.891	123.429	1.25
* 209	18.116	23.654	1.25	248	121.058	126.596	1.25
210	19.46	25.46	1.25	249	124.225	129.763	1.25
* 211	21.283	26.821	1.25	250	127.932	133.47	1.25
212	22.63	28.63	1.25	* 251	130.559	136.097	1.25
213	24.45	30	1.25	252	133.726	139.264	1.25
214	26.046	31.584	1.25	* 253	136.893	142.431	1.25
* 215	27.617	33.155	1.25	254	140.06	145.598	1.25
* 216	29.213	34.751	1.25	* 255	143.227	148.765	1.25
217	30.56	36.04	1.25	256	146.39	151.932	1.25
* 217A	30.784	36.322	1.25	257	149.7	155.18	1.25
218	32.38	37.918	1.25	* 257	149.561	155.099	1.25
* 219	33.951	39.489	1.25	* 258	152.728	158.266	1.25
* 220	35.547	41.085	1.25	258	152.86	158.34	1.25
* 221	37.118	42.656	1.25	259	159.063	164.604	1.25
222	38.714	44.252	1.25	* 260	165.397	170.935	1.25
223	41.8	47.8	1.25	* 261	171.731	177.269	1.25
224	45.048	50.56	1.25	262	178.26	184.26	1.25
225	48.215	53.753	1.25	263	184.399	189.937	1.25
226	51.382	56.92	1.25	* 264	190.733	196.271	1.25
227	54.549	60.087	1.25	265	197.31	203.31	1.25
228	57.717	63.255	1.25	* 266	203.401	208.939	1.25
229	60.88	66.418	1.25	267	210.01	215.49	1.25
230	64.051	69.589	1.25	268	216.36	221.84	1.25
231	67.2	72.68	1.25	* 269	222.404	227.942	1.25
232	70.385	75.923	1.25	* 270	228.738	234.276	1.25
233	73.552	79.09	1.25	* 271	235.072	240.61	1.25
234	76.719	82.257	1.25	272	241.76	247.24	1.25
235	79.53	85.53	1.25	* 273	247.74	253.278	1.25
236	83.053	88.591	1.25	* 274	254.074	259.612	1.25
237	86.22	91.758	1.25	* 279	330.084	335.622	1.25

BACKUP RING—AS-568 SERIES

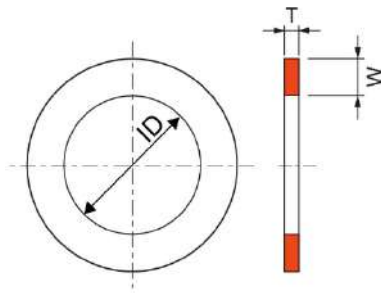

APPLICATION	
MATERIAL	HYTREL
TEMP.	-55°C~100°C

ITEM	ID	OD	h	ITEM	ID	OD	h
* 309	11.959	20.443	1.7	360	149.94	159.24	1.7
* 316	23.056	31.59	1.7	* 361	152.906	161.44	1.7
* 318	26.223	34.757	1.7	361	153.11	161.59	1.7
* 322	32.557	41.091	1.7	366	184.86	193.34	1.7
324	35.72	44.2	1.7	367	191.21	200.51	1.7
* 325	38.892	47.426	1.7	369	203.42	212.72	1.7
326	41.6	50.08	1.7	425	115.23	123.764	2.4
327	44.78	54.08	1.7	426	118.397	126.931	2.4
328	48.393	56.927	1.7	427	121.565	130.099	2.4
329	51.56	60.094	1.7	428	124.732	133.266	2.4
330	54.727	63.261	1.7	429	128.3	140.28	2.4
* 331	57.894	66.428	1.7	429	127.899	136.433	2.4
332	61.061	69.595	1.7	430	131.066	139.6	2.4
* 333	64.228	72.762	1.7	431	134.233	142.767	2.4
334	67.395	75.929	1.7	* 432	137.4	145.934	2.4
* 335	70.562	79.096	1.7	433	140.567	149.101	2.4
336	73.48	81.96	1.7	* 434	143.734	152.268	2.4
* 337	76.896	85.43	1.7	* 435	146.901	155.435	2.4
338	80.063	88.597	1.7	* 436	150.068	158.602	2.4
* 339	83.23	91.764	1.7	437	153.235	161.769	2.4
340	86.397	94.931	1.7	* 438	159.569	168.103	2.4
341	89.565	98.045	1.7	439	165.903	174.437	2.4
342	92.732	101.266	1.7	* 440	172.238	183.618	2.4
343	95.899	104.433	1.7	441	178.572	189.952	2.4
344	99.066	107.6	1.7	* 442	184.906	196.286	2.4
345	102.23	110.71	1.7	443	191.24	202.62	2.4
346	105.4	113.934	1.7	* 444	197.574	208.954	2.4
347	108.567	117.101	1.7	* 445	203.908	215.288	2.4
348	111.734	120.268	1.7	* 446	216.576	227.956	2.4
349	114.901	123.435	1.7	* 447	229.245	240.625	2.4
350	118.068	126.602	1.7	* 448	241.913	253.293	2.4
* 351	121.235	129.769	1.7	* 449	254.581	265.961	2.4
352	124.54	133.84	1.7	* 450	267.249	278.629	2.4
353	127.569	136.103	1.7	* 451	279.918	291.298	2.4
354	130.736	139.27	1.7	* 452	292.586	303.966	2.4
* 355	133.903	142.437	1.7	* 453	305.254	316.634	2.4
* 356	137.07	145.604	1.7	* 454	317.922	326.456	2.4
* 357	140.238	148.772	1.7	* 458	368.595	377.129	2.4
358	143.405	151.939	1.7	* 459	381.264	289.798	2.4
* 359	146.572	155.106	1.7	* 460	393.932	402.466	2.4

BACKUP RING P SERIES

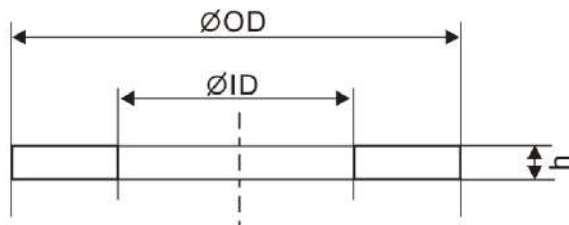

APPLICATION		
MATERIAL	PTFE	HY
TEMP.	-55°C~200°C	-40°C~100°C

ITEM	ID	OD	W	h	4F	HY
P-003	3	6	1.5	1.25	●	
P-004	4	7	1.5	1.25	●	
P-005	5	8	1.5	1.25	●	
P-006	6	9	1.5	1.25	●	
P-007	7	10	1.5	1.25	●	
P-008	8	11	1.5	1.25	●	
P-009	9	12	1.5	1.25	●	
P-010	10	13	1.5	1.25	●	●
P-010A	10	14	2	1.25	●	
P-011	11	15	2	1.25	●	
P-011.2	11.2	15.2	2	1.25	●	
P-012	12	16	2	1.25	●	
P-012.5	12.5	16.5	2	1.25	●	
P-013	13	17	2	1.25	●	
P-014	14	18	2	1.25	●	
P-015	15	19	2	1.25	●	●
P-016	16	20	2	1.25	●	
P-017	17	21	2	1.25	●	
P-018	18	22	2	1.25	●	
P-019	19	23	2	1.25	●	
P-020	20	24	2	1.25	●	●
P-021	21	25	2	1.25	●	
P-022	22	26	2	1.25	●	
P-022A	22	28	3	1.25	●	●
P-022.4	22.4	28.4	3	1.25	●	
P-024	24	30	3	1.25	●	
P-025	25	31	3	1.25	●	●
P-025.5	25.5	31.5	3	1.25	●	
P-026	26	32	3	1.25	●	
P-028	28	34	3	1.25	●	
P-029	29	35	3	1.25	●	
P-029.5	29.5	35.5	3	1.25	●	
P-030	30	36	3	1.25	●	
P-031	31	37	3	1.25	●	
P-031.5	31.5	37.5	3	1.25	●	
P-032	32	38	3	1.25	●	
P-034	34	40	3	1.25	●	
P-035	35	41	3	1.25	●	
P-035.5	35.5	41.5	3	1.25	●	
P-036	36	42	3	1.25	●	●
P-038	38	44	3	1.25	●	
P-039	39	45	3	1.25	●	●
P-040	40	46	3	1.25	●	●
P-041	41	47	3	1.25	●	●

BACKUP RING P SERIES

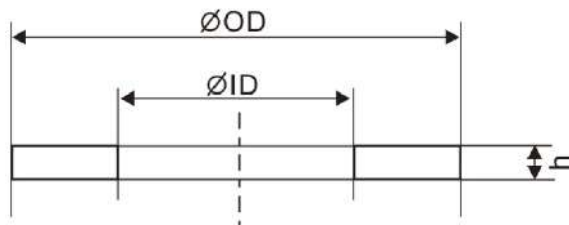

APPLICATION		
MATERIAL	PTFE	HY
TEMP.	-55°C~200°C	-40°C~100°C

ITEM	ID	OD	W	h	4F	HY
P-042	42	48	3	1.25	●	●
P-044	44	50	3	1.25	●	●
P-045	45	51	3	1.25	●	●
P-046	46	52	3	1.25	●	●
P-048	48	54	3	1.25	●	●
P-049	49	55	3	1.25	●	●
P-050	50	56	3	1.25	●	●
P-018	18	22	2	1.5	●	●
P-105	105	111	3	1.5	●	●
P-048A	48	58	5	1.9	●	●
P-050A	50	60	5	1.9	●	●
P-052	52	62	5	1.9	●	●
P-053	53	63	5	1.9	●	●
P-055	55	65	5	1.9	●	●
P-056	56	66	5	1.9	●	●
P-058	58	68	5	1.9	●	●
P-060	60	70	5	1.9	●	●
P-062	62	72	5	1.9	●	●
P-063	63	73	5	1.9	●	●
P-065	65	75	5	1.9	●	●
P-067	67	77	5	1.9	●	●
P-070	70	80	5	1.9	●	●
P-071	71	81	5	1.9	●	●
P-075	75	85	5	1.9	●	●
P-080	80	90	5	1.9	●	●
P-085	85	95	5	1.9	●	●
P-090	90	100	5	1.9	●	●
P-095	95	105	5	1.9	●	●
P-100	100	110	5	1.9	●	●
P-102	102	112	5	1.9	●	●
P-105	105	115	5	1.9	●	●
P-110	110	120	5	1.9	●	●
P-112	112	122	5	1.9	●	●
P-115	115	125	5	1.9	●	●
P-120	120	130	5	1.9	●	●
P-125	125	135	5	1.9	●	●
P-130	130	140	5	1.9	●	●
P-132	132	142	5	1.9	●	●
P-135	135	145	5	1.9	●	●
P-140	140	150	5	1.9	●	●
P-145	145	155	5	1.9	●	●
P-150	150	160	5	1.9	●	●
P-150A	150	165	7.5	2.75	●	●
P-155	155	170	7.5	2.75	●	●

BACKUP RING P SERIES

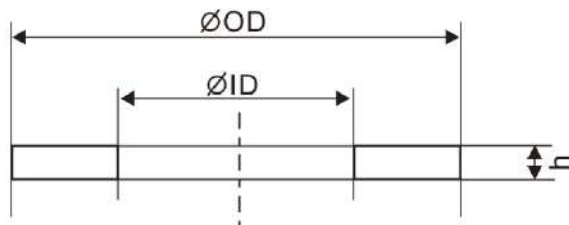

APPLICATION		
MATERIAL	PTFE	HY
TEMP.	-55°C~200°C	-40°C~100°C

ITEM	ID	OD	W	h	4F	HY
P-160	160	175	7.5	2.75	●	●
P-165	165	180	7.5	2.75	●	
P-170	170	185	7.5	2.75	●	●
P-175	175	190	7.5	2.75	●	
P-180	180	195	7.5	2.75	●	●
P-185	185	200	7.5	2.75	●	
P-190	190	205	7.5	2.75	●	
P-195	195	210	7.5	2.75	●	●
P-200	200	215	7.5	2.75	●	
P-205	205	220	7.5	2.75	●	
P-209	209	224	7.5	2.75	●	
P-210	210	225	7.5	2.75	●	
P-215	215	230	7.5	2.75	●	
P-220	220	235	7.5	2.75	●	
P-225	225	240	7.5	2.75	●	●
P-225	225	240	7.5	2.75	●	●
P-230	230	245	7.5	2.75	●	
P-230	230	245	7.5	2.75	●	
P-235	235	250	7.5	2.75	●	
P-235	235	250	7.5	2.75	●	
P-240	240	255	7.5	2.75	●	
P-240	240	255	7.5	2.75	●	
P-245	245	260	7.5	2.75	●	
P-245	245	260	7.5	2.75	●	
P-250	250	265	7.5	2.75	●	
P-255	255	270	7.5	2.75	●	
P-255	255	270	7.5	2.75	●	
P-260	260	275	7.5	2.75	●	
P-260	260	275	7.5	2.75	●	
P-265	265	280	7.5	2.75	●	
P-265	265	280	7.5	2.75	●	
P-270	270	285	7.5	2.75	●	
P-270	270	285	7.5	2.75	●	
P-275	275	290	7.5	2.75	●	
P-275	275	290	7.5	2.75	●	
P-280	280	295	7.5	2.75	●	
P-280	280	295	7.5	2.75	●	
P-285	285	300	7.5	2.75	●	
P-285	285	300	7.5	2.75	●	
P-290	290	305	7.5	2.75	●	
P-290	290	305	7.5	2.75	●	
P-295	295	310	7.5	2.75	●	
P-295	295	310	7.5	2.75	●	
P-300	300	315	7.5	2.75	●	

BACKUP RING P SERIES

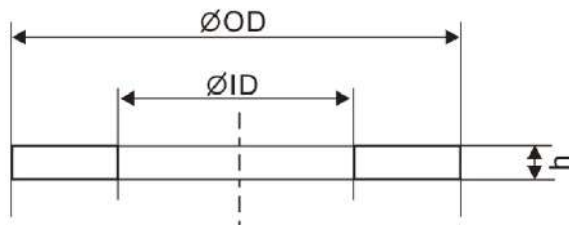

APPLICATION		
MATERIAL	PTFE	HY
TEMP.	-55°C~200°C	-40°C~100°C

ITEM	ID	OD	W	h	4F	HY
P-305	305	320	7.5	2.75	●	
P-310	310	325	7.5	2.75	●	
P-315	315	330	7.5	2.75	●	
P-320	320	335	7.5	2.75	●	
P-320	320	335	7.5	2.75	●	
P-325	325	340	7.5	2.75	●	
P-330	330	345	7.5	2.75	●	
P-335	335	350	7.5	2.75	●	
P-340	340	355	7.5	2.75	●	
P-345	345	360	7.5	2.75	●	
P-350	350	365	7.5	2.75	●	
P-355	355	370	7.5	2.75	●	
P-360	360	375	7.5	2.75	●	
P-375	375	390	7.5	2.75	●	
P-385	385	400	7.5	2.75	●	
P-400	400	415	7.5	2.75	●	
P-405	405	420	7.5	2.75	●	
P-410	410	425	7.5	2.75	●	●
P-415	415	430	7.5	2.75	●	●
P-420	420	435	7.5	2.75		●
P-425	425	440	7.5	3	●	●
P-430	430	445	7.5	2.75	●	●
P-435	435	450	7.5	2.75	●	●
P-440	440	455	7.5	2.75	●	
P-445	445	460	7.5	2.75	●	●
P-450	450	465	7.5	2.75		
P-455	455	470	7.5	2.75		
P-460	460	475	7.5	2.75		
P-465	465	480	7.5	2.75	●	
P-470	470	485	7.5	2.75	●	
P-475	475	490	7.5	2.75	●	
P-480	480	495	7.5	2.75		
P-485	485	500	7.5	2.75	●	
P-490	490	505	7.5	2.75	●	
P-495	495	510	7.5	2.75	●	
P-500	500	515	7.5	2.75	●	
P-525	525	540	7.5	2.75	●	
P-530	530	545	7.5	2.75	●	
P-535	535	550	7.5	2.75	●	
P-555	555	570	7.5	2.75	●	

BACKUP RING G SERIES

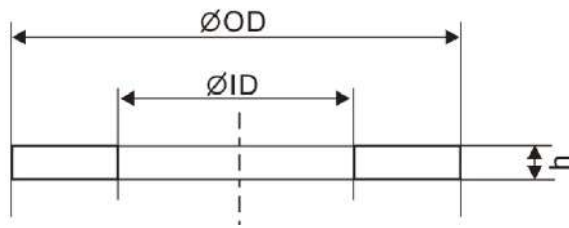

APPLICATION		
MATERIAL	PTFE	HY
TEMP.	-55°C~200°C	-40°C~100°C

ITEM	ID	OD	W	h	4F	HY
G-014	14	18	2	1.25		●
G-025	25	30	2.5	1.25	●	●
G-026	26	31	2.5	1.25	●	
G-028	28	32	2	1.25	●	
G-030	30	35	2.5	1.25	●	●
G-035	35	40	2.5	1.25	●	●
G-038	38	43	2.5	1.25		●
G-040	40	45	2.5	1.25	●	●
G-042	42	47	2.5	1.25	●	
G-043	43	48	2.5	1.25	●	
G-045	45	50	2.5	1.25	●	●
G-050	50	55	2.5	1.25	●	●
G-051	51	56	2.5	1.25		
G-055	55	60	2.5	1.25	●	●
G-056	56	61	2.5	1.25		●
G-058	58	63	2.5	1.25	●	●
G-060	60	65	2.5	1.25	●	●
G-063	63	68	2.5	1.25	●	●
G-065	65	70	2.5	1.25	●	●
G-066	66	71	2.5	1.25		●
G-067	67	72	2.5	1.25	●	
G-070	70	75	2.5	1.25	●	●
G-071	71	76	2.5	1.25		
G-072	72	77	2.5	1.25	●	
G-075	75	80	2.5	1.25	●	●
G-076	76	81	2.5	1.25		●
G-080	80	85	2.5	1.25	●	●
G-081	81	86	2.5	1.25		
G-085	85	90	2.5	1.25	●	●
G-086	86	91	2.5	1.25		●
G-087	87	92	2.5	1.25		●
G-090	90	95	2.5	1.25	●	●
G-091	91	96	2.5	1.25		
G-095	95	100	2.5	1.25	●	●
G-096	96	101	2.5	1.25		●
G-100	100	105	2.5	1.25	●	●
G-105	105	110	2.5	1.25	●	●
G-106	106	111	2.5	1.25		●
G-108	108	113	2.5	1.25		●
G-110	110	115	2.5	1.25	●	●
G-115	115	120	2.5	1.25	●	●

BACKUP RING G SERIES

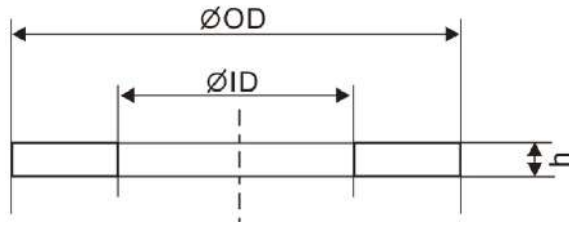

APPLICATION		
MATERIAL	PTFE	HY
TEMP.	-55°C~200°C	-40°C~100°C

ITEM	ID	OD	W	h	4F	HY
G-116	116	121	2.5	1.25		
G-120	120	125	2.5	1.25	●	●
G-125	125	130	2.5	1.25	●	●
G-126	126	131	2.5	1.25		●
G-128	128	133	2.5	1.25		●
G-130	130	135	2.5	1.25	●	●
G-135	135	140	2.5	1.25	●	●
G-136	136	141	2.5	1.25		
G-140	140	145	2.5	1.25	●	●
G-145	145	150	2.5	1.25	●	●
G-146	146	151	2.5	1.25		●
GS-150	150	155	2.5	1.25	●	
GS-160	160	165	2.5	1.25	●	
GS-170	170	175	2.5	1.25	●	
G-040	40	45	2.5	1.5	●	
G-045A	45	50	2.5	1.5		●
G-050A	50	55	2.5	1.5		●
G-055A	55	60	2.5	1.5		●
G-060A	60	65	2.5	1.5		●
G-065A	65	70	2.5	1.5		●
G-070	70	75	2.5	1.5	●	●
G-075A	75	80	2.5	1.5		●
G-080	80	85	2.5	1.5	●	●
G-085	85	90	2.5	1.5	●	●
G-090	90	95	2.5	1.5	●	●
G-095	95	100	2.5	1.5	●	●
G-100	100	105	2.5	1.5	●	●
G-105	105	110	2.5	1.5	●	●
G-106	106	111	2.5	1.5		●
G-110	110	115	2.5	1.5	●	●
G-115	115	120	2.5	1.5	●	●
G-120	120	125	2.5	1.5	●	●
G-125	125	130	2.5	1.5	●	●
G-126A	126	131	2.5	1.5		
G-130	130	135	2.5	1.5	●	●
G-135	135	140	2.5	1.5	●	●
G-140	140	145	2.5	1.5	●	●
G-145	145	150	2.5	1.5	●	●
G-155	155	165	5	1.5	●	●
G-160A	160	170	5	1.5		●
G-080	80	85	2.5	1.9		●

BACKUP RING G SERIES

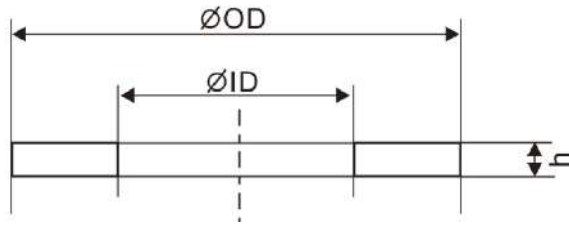

APPLICATION		
MATERIAL	PTFE	HY
TEMP.	-55°C~200°C	-40°C~100°C

ITEM	ID	OD	W	h	4F	HY
G-085	85	90	2.5	1.9		●
G-090	90	95	2.5	1.9		●
G-095	95	100	2.5	1.9		●
G-110	110	115	2.5	1.9	●	●
G-150	150	160	5	1.9	●	
G-155	155	165	5	1.9	●	●
G-160	160	170	5	1.9	●	●
G-165	165	175	5	1.9	●	●
G-170	170	180	5	1.9	●	●
G-175	175	185	5	1.9	●	●
G-180	180	190	5	1.9	●	●
G-185	185	195	5	1.9	●	●
G-190	190	200	5	1.9	●	●
G-195	195	205	5	1.9	●	●
G-200	200	210	5	1.9	●	●
G-205	205	215	5	1.9	●	
G-210	210	220	5	1.9	●	●
G-215	215	225	5	1.9	●	
G-220	220	230	5	1.9	●	●
G-225	225	235	5	1.9	●	
G-230	230	240	5	1.9	●	●
G-235	235	245	5	1.9	●	
G-240	240	250	5	1.9	●	●
G-245	245	255	5	1.9	●	
G-250	250	260	5	1.9	●	●
G-255	255	265	5	1.9	●	
G-260	260	270	5	1.9	●	●
G-265	265	275	5	1.9	●	
G-270	270	280	5	1.9	●	●
G-275	275	285	5	1.9	●	
G-280	280	290	5	1.9	●	●
G-285	285	295	5	1.9	●	
G-290	290	300	5	1.9	●	●
G-300	300	310	5	1.9	●	●
G-305	305	315	5	1.9	●	
G-310	310	320	5	1.9	●	
G-5200	520	530	5	1.9	●	
G-161	161	170.56	4.78	1.95		●
G-315	315	325	5	2	●	
G-320	320	330	5	2	●	
G-325	325	335	5	2		

BACKUP RING G SERIES

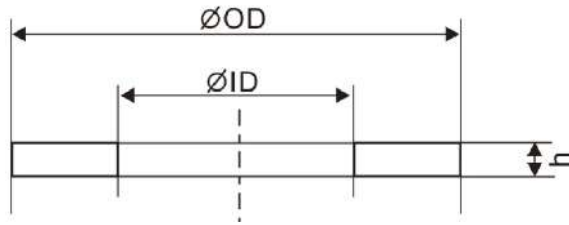

APPLICATION		
MATERIAL	PTFE	HY
TEMP.	-55°C~200°C	-40°C~100°C

ITEM	ID	OD	W	h	4F	HY
G-330	330	340	5	2	●	
G-335	335	345	5	2	●	
G-340	340	350	5	2	●	
G-345	345	355	5	2		
G-350	350	360	5	2		
G-355	355	365	5	2		
G-360	360	370	5	2	●	
G-365	365	375	5	2		
G-370	370	380	5	2		
G-375	375	385	5	2	●	
G-380	380	390	5	2		
G-385	385	395	5	2		
G-390	390	400	5	2	●	
G-395	395	405	5	2		
G-400	400	410	5	2	●	
G-405	405	415	5	2		
G-410	410	420	5	2	●	
G-415	415	425	5	2		
G-420	420	430	5	2	●	
G-425	425	435	5	2		
G-430	430	440	5	2	●	
G-435	435	445	5	2		
G-440	440	450	5	2		
G-445	445	455	5	2		
G-450	450	460	5	2		
G-455	455	465	5	2	●	
G-460	460	470	5	2	●	
G-465	465	475	5	2		
G-470	470	480	5	2	●	
G-475	475	485	5	2		
G-480	480	490	5	2	●	
G-485	485	495	5	2		
G-490	490	500	5	2	●	
G-495	495	505	5	2		
G-500	500	510	5	2		
G-520	520	530	5	2	●	
G-530	530	540	5	2	●	
G-155A	155	165	5	2.5		
G-160A	160	170	5	2.5		●
G-170A	170	180	5	2.5		
G-180A	180	190	5	2.5		●

BACKUP RING G SERIES

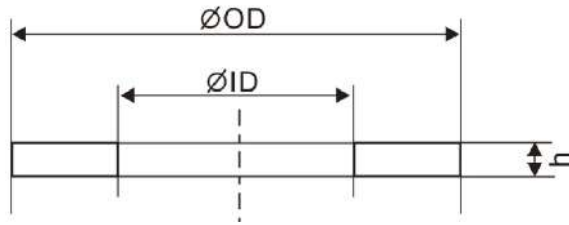

APPLICATION		
MATERIAL	PTFE	HY
TEMP.	-55°C~200°C	-40°C~100°C

ITEM	ID	OD	W	h	4F	HY
G-190A	190	200	5	2.5		
G-205A	205	215	5	2.5		●
G-215A	215	225	5	2.5		
G-220A	220	230	5	2.5		
G-230A	230	240	5	2.5		
G-240A	240	250	5	2.5		
G-250A	250	260	5	2.5		
G-270A	270	280	5	2.5		

PETSEALS

BACKUP RING—4F-AS SERIES

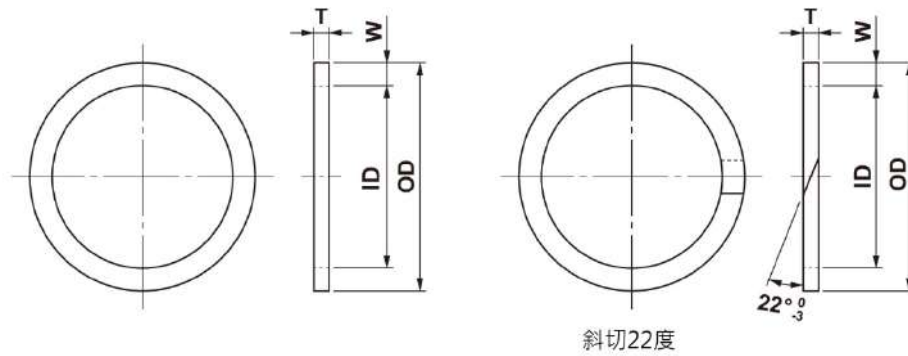

MATERIAL	PTFE
TEMP.	-55°C~200°C

ITEM	ID	W	T	ITEM	ID	W	T
4F-AS-005	3.15	1.35	1.27	* 4F-AS-041	76.66	1.35	1.27
4F-AS-006	3.56	1.35	1.27	* 4F-AS-042	83.01	1.35	1.27
4F-AS-007	4.34	1.35	1.27	* 4F-AS-043	89.36	1.35	1.27
4F-AS-008	5.13	1.35	1.27	* 4F-AS-044	95.71	1.35	1.27
4F-AS-009	5.94	1.35	1.27	* 4F-AS-045	102.06	1.35	1.27
4F-AS-010	6.73	1.35	1.27	* 4F-AS-046	108.41	1.35	1.27
4F-AS-011	8.30	1.35	1.27	* 4F-AS-047	114.76	1.35	1.27
4F-AS-012	9.90	1.35	1.27	* 4F-AS-048	121.11	1.35	1.27
4F-AS-013	11.56	1.35	1.27	* 4F-AS-102	1.96	2.18	1.35
4F-AS-014	13.16	1.35	1.27	* 4F-AS-103	2.77	2.18	1.35
4F-AS-015	14.73	1.35	1.27	* 4F-AS-104	3.56	2.18	1.35
4F-AS-016	16.33	1.35	1.27	* 4F-AS-105	4.34	2.18	1.35
4F-AS-016F	16.00	1.4	1.27	* 4F-AS-106	5.13	2.18	1.35
4F-AS-017	17.91	1.35	1.27	* 4F-AS-107	5.94	2.18	1.35
4F-AS-018	19.51	1.35	1.27	* 4F-AS-108	6.73	2.18	1.35
4F-AS-019	21.08	1.35	1.27	* 4F-AS-109	8.31	2.18	1.35
4F-AS-020	22.68	1.35	1.27	4F-AS-110	9.91	2.18	1.35
4F-AS-021	24.26	1.35	1.27	4F-AS-111	11.48	2.18	1.35
4F-AS-022	25.98	1.35	1.27	4F-AS-112	13.08	2.18	1.35
4F-AS-023	27.56	1.35	1.27	4F-AS-113	14.66	2.18	1.35
4F-AS-024	29.03	1.35	1.27	4F-AS-114	16.26	2.18	1.35
4F-AS-025	30.61	1.35	1.27	4F-AS-115	17.83	2.18	1.35
4F-AS-026	32.21	1.35	1.27	4F-AS-116	19.43	2.18	1.35
4F-AS-027	33.78	1.35	1.27	4F-AS-117	21.11	2.18	1.35
4F-AS-028	35.38	1.35	1.27	4F-AS-118	22.68	2.18	1.35
4F-AS-029	38.56	1.35	1.27	4F-AS-119	24.28	2.18	1.35
4F-AS-030	41.73	1.35	1.27	4F-AS-120	25.86	2.18	1.35
4F-AS-031	44.91	1.35	1.27	4F-AS-121	27.46	2.18	1.35
4F-AS-032	48.08	1.35	1.27	4F-AS-122	29.03	2.18	1.35
4F-AS-033	51.26	1.35	1.27	4F-AS-123	30.63	2.18	1.35
4F-AS-034	54.43	1.35	1.27	4F-AS-124	32.21	2.18	1.35
4F-AS-035	57.61	1.35	1.27	4F-AS-125	33.81	2.18	1.35
* 4F-AS-036	60.78	1.35	1.27	4F-AS-126	35.38	2.18	1.35
* 4F-AS-037	63.96	1.35	1.27	4F-AS-127	36.98	2.18	1.35
* 4F-AS-038	67.13	1.35	1.27	4F-AS-128	38.56	2.18	1.35
* 4F-AS-039	70.31	1.35	1.27	4F-AS-129	40.16	2.18	1.35
* 4F-AS-040	73.48	1.35	1.27	4F-AS-130	41.73	2.18	1.35

BACKUP RING—4F-AS SERIES

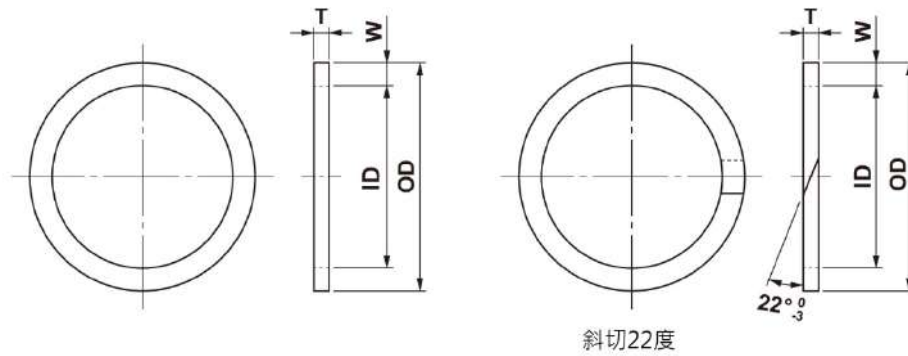

MATERIAL	PTFE
TEMP.	-55°C~200°C

ITEM	ID	W	T	ITEM	ID	W	T
4F-AS-131	43.33	2.18	1.35	4F-AS-168	184.61	2.18	1.35
4F-AS-132	44.91	2.18	1.35	* 4F-AS-169	190.96	2.18	1.35
4F-AS-133	46.51	2.18	1.35	* 4F-AS-170	197.31	2.18	1.35
4F-AS-134	48.08	2.18	1.35	* 4F-AS-171	203.66	2.18	1.35
4F-AS-135	49.68	2.18	1.35	* 4F-AS-172	210.01	2.18	1.35
4F-AS-136	51.26	2.18	1.35	* 4F-AS-173	216.36	2.18	1.35
4F-AS-137	52.86	2.18	1.35	* 4F-AS-174	222.71	2.18	1.35
4F-AS-138	54.43	2.18	1.35	* 4F-AS-175	229.06	2.18	1.35
* 4F-AS-139	56.03	2.18	1.35	* 4F-AS-176	235.41	2.18	1.35
4F-AS-140	57.61	2.18	1.35	* 4F-AS-177	241.76	2.18	1.35
4F-AS-141	59.21	2.18	1.35	* 4F-AS-178	248.11	2.18	1.35
4F-AS-142	60.78	2.18	1.35	4F-AS-207	14.70	3	1.27
4F-AS-143	62.38	2.18	1.35	4F-AS-208	16.33	3	1.27
4F-AS-144	63.96	2.18	1.35	4F-AS-209	17.90	3	1.27
4F-AS-145	65.56	2.18	1.35	4F-AS-210	19.46	3	1.27
4F-AS-146	67.13	2.18	1.35	4F-AS-211	21.03	3	1.27
4F-AS-147	68.73	2.18	1.35	4F-AS-212	22.63	3	1.27
4F-AS-148	70.31	2.18	1.35	4F-AS-213	24.21	3	1.27
4F-AS-149	71.91	2.18	1.35	4F-AS-214	25.81	3	1.27
4F-AS-150	73.48	2.18	1.35	4F-AS-215	27.38	3	1.27
4F-AS-151	76.66	2.18	1.35	4F-AS-216	28.98	3	1.27
4F-AS-152	83.01	2.18	1.35	4F-AS-217	30.56	3	1.27
4F-AS-153	89.36	2.18	1.35	4F-AS-218	32.16	3	1.27
4F-AS-154	95.71	2.18	1.35	4F-AS-219	33.88	3	1.27
4F-AS-155	102.06	2.18	1.35	4F-AS-220	35.48	3	1.27
4F-AS-156	108.41	2.18	1.35	4F-AS-221	37.06	3	1.27
4F-AS-157	114.76	2.18	1.35	4F-AS-222	38.66	3	1.27
* 4F-AS-158	121.11	2.18	1.35	4F-AS-223	41.83	3	1.27
* 4F-AS-159	127.46	2.18	1.35	4F-AS-224	45.01	3	1.27
* 4F-AS-160	133.81	2.18	1.35	4F-AS-225	48.18	3	1.27
* 4F-AS-161	140.16	2.18	1.35	4F-AS-226	51.36	3	1.27
* 4F-AS-162	146.51	2.18	1.35	4F-AS-227	54.53	3	1.27
4F-AS-163	152.86	2.18	1.35	4F-AS-228	57.71	3	1.27
* 4F-AS-164	159.21	2.18	1.35	4F-AS-229	60.88	3	1.27
4F-AS-165	165.56	2.18	1.35	4F-AS-230	64.06	3	1.27
4F-AS-166	171.91	2.18	1.35	4F-AS-231	66.83	3	1.27
* 4F-AS-167	178.26	2.18	1.35	4F-AS-232	70.00	3	1.27

BACKUP RING—4F-AS SERIES

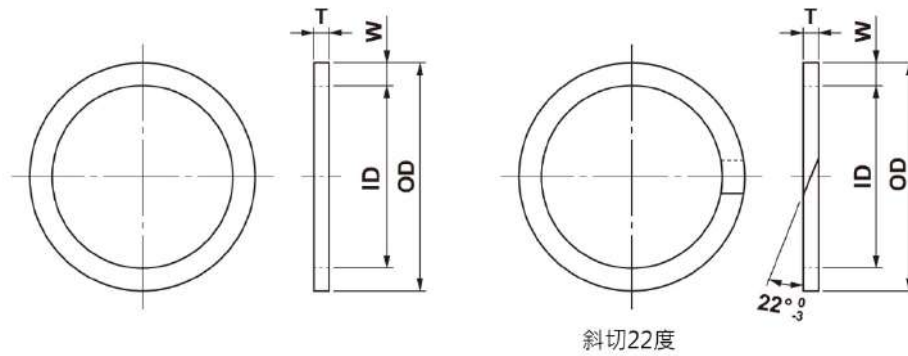

MATERIAL	PTFE
TEMP.	-55°C~200°C

ITEM	ID	W	T	ITEM	ID	W	T
4F-AS-233	73.18	3	1.27	4F-AS-270	229.06	3	1.27
4F-AS-234	76.35	3	1.27	4F-AS-271	235.41	3	1.27
4F-AS-235	79.53	3	1.27	4F-AS-272	241.76	3	1.27
4F-AS-236	82.70	3	1.27	4F-AS-273	248.11	3	1.27
4F-AS-237	85.88	3	1.27	4F-AS-274	254.46	3	1.27
4F-AS-238	89.05	3	1.27	4F-AS-275	267.16	3	1.27
4F-AS-239	92.23	3	1.27	4F-AS-276	279.86	3	1.27
4F-AS-240	95.40	3	1.27	* 4F-AS-277	292.56	3	1.27
* 4F-AS-241	98.58	3	1.27	* 4F-AS-278	305.26	3	1.27
4F-AS-242	101.75	3	1.27	* 4F-AS-279	330.66	3	1.27
4F-AS-243	104.93	3	1.27	* 4F-AS-280	356.05	3	1.27
* 4F-AS-244	108.10	3	1.27	* 4F-AS-281	381.46	3	1.27
* 4F-AS-245	111.28	3	1.27	4F-AS-282	406.12	3	1.27
4F-AS-246	114.45	3	1.27	* 4F-AS-283	431.52	3	1.27
4F-AS-247	117.63	3	1.27	* 4F-AS-284	456.92	3	1.27
* 4F-AS-248	121.11	3	1.27	* 4F-AS-309	11.43	4.65	1.93
* 4F-AS-249	124.28	3	1.27	* 4F-AS-310	13.03	4.65	1.93
4F-AS-250	127.46	3	1.27	* 4F-AS-311	14.60	4.65	1.93
4F-AS-251	130.63	3	1.27	* 4F-AS-312	16.20	4.65	1.93
4F-AS-252	133.81	3	1.27	* 4F-AS-313	17.78	4.65	1.93
* 4F-AS-253	136.98	3	1.27	* 4F-AS-314	19.38	4.65	1.93
* 4F-AS-254	140.16	3	1.27	* 4F-AS-315	20.96	4.65	1.93
4F-AS-255	143.33	3	1.27	* 4F-AS-316	22.56	4.65	1.93
* 4F-AS-256	146.51	3	1.27	* 4F-AS-317	24.13	4.65	1.93
4F-AS-257	149.68	3	1.27	* 4F-AS-318	25.73	4.65	1.93
4F-AS-258	152.86	3	1.27	* 4F-AS-319	27.31	4.65	1.93
4F-AS-259	159.21	3	1.27	* 4F-AS-320	28.91	4.65	1.93
4F-AS-260	165.56	3	1.27	* 4F-AS-321	30.42	4.65	1.93
4F-AS-261	171.91	3	1.27	4F-AS-322	32.08	4.65	1.93
4F-AS-262	178.26	3	1.27	4F-AS-323	33.43	4.65	1.93
4F-AS-263	184.61	3	1.27	4F-AS-324	35.26	4.65	1.93
4F-AS-264	190.96	3	1.27	4F-AS-325	38.43	4.65	1.93
4F-AS-265	197.31	3	1.27	4F-AS-326	41.61	4.65	1.93
4F-AS-266	203.66	3	1.27	4F-AS-327	44.78	4.65	1.93
4F-AS-267	210.01	3	1.27	4F-AS-328	47.96	4.65	1.93
4F-AS-268	216.36	3	1.27	4F-AS-329	51.13	4.65	1.93
4F-AS-269	222.71	3	1.27	4F-AS-330	54.31	4.65	1.93

BACKUP RING—4F-AS SERIES

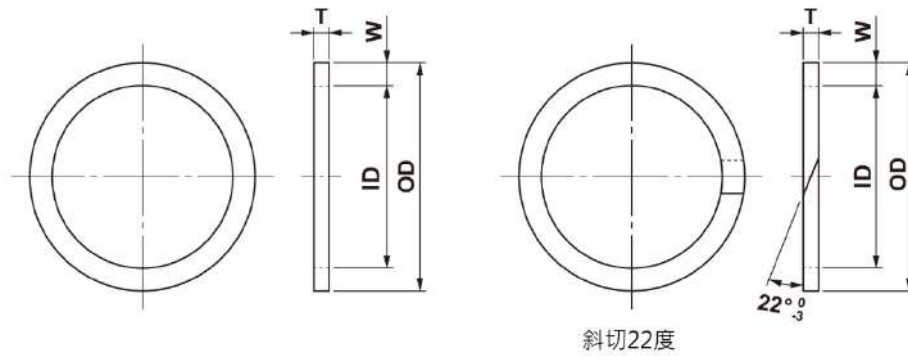

MATERIAL	PTFE
TEMP.	-55°C~200°C

ITEM	ID	W	T	ITEM	ID	W	T
* 4F-AS-331	57.61	4.65	1.93	4F-AS-368	197.56	4.65	1.93
4F-AS-332	60.78	4.65	1.93	4F-AS-369	203.91	4.65	1.93
4F-AS-333	63.96	4.65	1.93	4F-AS-370	210.26	4.65	1.93
* 4F-AS-334	67.13	4.65	1.93	4F-AS-371	216.61	4.65	1.93
4F-AS-335	70.31	4.65	1.93	4F-AS-372	222.96	4.65	1.93
4F-AS-336	73.48	4.65	1.93	4F-AS-373	229.31	4.65	1.93
4F-AS-337	76.66	4.65	1.93	4F-AS-374	235.66	4.65	1.93
4F-AS-338	79.83	4.65	1.93	4F-AS-375	242.01	4.65	1.93
4F-AS-339	82.98	4.65	1.93	* 4F-AS-376	248.36	4.65	1.93
4F-AS-340	86.31	4.65	1.93	4F-AS-377	254.71	4.65	1.93
4F-AS-341	89.48	4.65	1.93	4F-AS-378	267.41	4.65	1.93
4F-AS-342	92.66	4.65	1.93	4F-AS-379	280.11	4.65	1.93
* 4F-AS-343	95.83	4.65	1.93	4F-AS-380	292.81	4.65	1.93
* 4F-AS-344	99.01	4.65	1.93	* 4F-AS-381	305.51	4.65	1.93
4F-AS-345	102.31	4.65	1.93	4F-AS-382	330.91	4.65	1.93
4F-AS-346	105.49	4.65	1.93	4F-AS-383	356.31	4.65	1.93
4F-AS-347	108.66	4.65	1.93	* 4F-AS-384	381.71	4.65	1.93
4F-AS-348	111.84	4.65	1.93	* 4F-AS-385	406.60	4.65	1.93
4F-AS-349	115.01	4.65	1.93	* 4F-AS-386	432.00	4.65	1.93
4F-AS-350	118.19	4.65	1.93	* 4F-AS-387	457.40	4.65	1.93
4F-AS-351	121.36	4.65	1.93	* 4F-AS-388	482.75	4.65	1.93
4F-AS-352	124.54	4.65	1.93	* 4F-AS-389	508.15	4.65	1.93
4F-AS-353	127.71	4.65	1.93	* 4F-AS-390	533.55	4.65	1.93
4F-AS-354	130.89	4.65	1.93	* 4F-AS-391	558.95	4.65	1.93
4F-AS-355	134.09	4.65	1.93	* 4F-AS-392	584.02	4.65	1.93
4F-AS-356	137.24	4.65	1.93	* 4F-AS-393	609.42	4.65	1.93
4F-AS-357	140.41	4.65	1.93	* 4F-AS-394	634.82	4.65	1.93
4F-AS-358	143.59	4.65	1.93	* 4F-AS-395	660.22	4.65	1.93
4F-AS-359	146.76	4.65	1.93	* 4F-AS-425	115.60	5.99	2.97
4F-AS-360	149.94	4.65	1.93	* 4F-AS-426	118.77	5.99	2.97
4F-AS-361	153.11	4.65	1.93	4F-AS-427	121.95	5.99	2.97
4F-AS-362	159.46	4.65	1.93	* 4F-AS-428	125.20	5.99	2.97
4F-AS-363	165.81	4.65	1.93	* 4F-AS-429	128.30	5.99	2.97
4F-AS-364	172.16	4.65	1.93	* 4F-AS-430	131.47	5.99	2.97
4F-AS-365	178.51	4.65	1.93	* 4F-AS-431	134.65	5.99	2.97
4F-AS-366	184.86	4.65	1.93	4F-AS-432	137.82	5.99	2.97
4F-AS-367	191.21	4.65	1.93	* 4F-AS-433	141.00	5.99	2.97

BACKUP RING—4F-AS SERIES

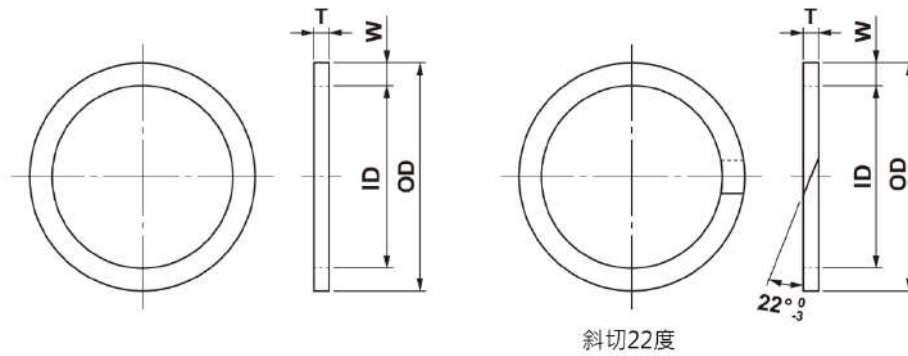

MATERIAL	PTFE
TEMP.	-55°C~200°C

ITEM	ID	W	T	ITEM	ID	W	T
4F-AS-434	144.17	5.99	2.97	* 4F-AS-452	292.71	5.99	2.97
* 4F-AS-435	147.35	5.99	2.97	4F-AS-453	305.41	5.99	2.97
* 4F-AS-436	150.52	5.99	2.97	4F-AS-454	318.11	5.99	2.97
* 4F-AS-437	153.70	5.99	2.97	4F-AS-455	330.81	5.99	2.97
4F-AS-438	159.36	5.99	2.97	4F-AS-456	343.51	5.99	2.97
4F-AS-439	165.71	5.99	2.97	4F-AS-457	356.21	5.99	2.97
* 4F-AS-440	172.06	5.99	2.97	* 4F-AS-458	368.91	5.99	2.97
4F-AS-441	178.41	5.99	2.97	* 4F-AS-459	381.61	5.99	2.97
4F-AS-442	184.76	5.99	2.97	* 4F-AS-460	394.31	5.99	2.97
4F-AS-443	191.11	5.99	2.97	4F-AS-461	406.50	5.99	2.97
* 4F-AS-444	197.46	5.99	2.97	* 4F-AS-462	419.20	5.99	2.97
* 4F-AS-445	203.81	5.99	2.97	4F-AS-463	431.90	5.99	2.97
4F-AS-446	216.51	5.99	2.97	4F-AS-464	445.11	5.99	2.97
4F-AS-447	229.21	5.99	2.97	* 4F-AS-465	457.30	5.99	2.97
* 4F-AS-448	241.91	5.99	2.97	* 4F-AS-466	470.00	5.99	2.97
* 4F-AS-449	254.61	5.99	2.97	* 4F-AS-467	482.70	5.99	2.97
4F-AS-450	267.31	5.99	2.97	* 4F-AS-468	495.40	5.99	2.97
* 4F-AS-451	280.01	5.99	2.97	* 4F-AS-469	508.10	5.99	2.97

ROD SEAL BACKUP RING

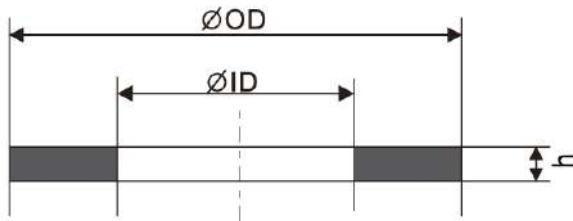

APPLICATION		
MATERIAL	NY	POK
TEMP.	-55°C~120°C	-30~120°C

ITEM	ID	OD	h	ITEM	ID	OD	h
NY-35	35	45	3	NY-75	75	95	3
NY-40	40	50	3	NY-80	80	90	3
NY-40	40	55	3	NY-80	80	93	3
NY-45	45	55	3	NY-80	80	95	3
NY-45	45	60	3	NY-80	80	100	3
NY-45	45	65	3	NY-85	85	100	3
NY-50	50	60	3	NY-85	85	105	3
NY-50	50	63	3	NY-90	90	105	3
NY-50	50	65	3	NY-90	90	110	3
NY-50	50	70	3	NY-95	95	110	3
NY-55	55	65	3	NY-95	95	115	3
NY-55	55	68	3	NY-100	100	110	3
NY-55	55	70	3	NY-100	100	115	3
NY-55	55	71	3	NY-100	100	120	3
NY-55	55	75	3	NY-105	105	120	3
NY-55	55	80	3	NY-105	105	125	3
NY-60	60	70	3	NY-110	110	125	3
NY-60	60	73	3	NY-110	110	130	3
NY-60	60	75	3	NY-115	115	125	3
NY-60	60	76	3	NY-115	115	130	3
NY-60	60	80	3	NY-115	115	135	3
NY-63	63	73	3	NY-120	120	135	3
NY-64	64	80	3	NY-120	120	140	3
NY-65	65	73	3	NY-125	125	140	3
NY-65	65	75	3	NY-125	125	145	3
NY-65	65	78	3	NY-125	125	250	3
NY-65	65	80	3	NY-130	130	145	3
NY-65	65	85	3	NY-130	130	150	3
NY-65	65	90	3	NY-135	135	150	3
NY-70	70	80	3	NY-140	140	160	3
NY-70	70	83	3	NY-145	145	160	3
NY-70	70	85	3	NY-150	150	165	3
NY-70	70	90	3	NY-150	150	170	3
NY-75	75	85	3	NY-155	155	170	3
NY-75	75	88	3	NY-160	160	180	3
NY-75	75	90	3				

BACKUP RING—POLYURETHANE P,G,80 SERIES(PU)

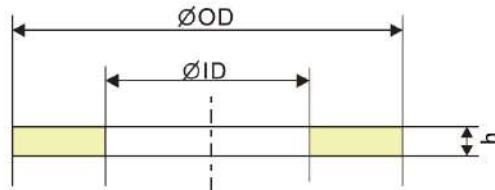

APPLICATION	
MATERIAL	PU
TEMP.	-35°C~100°C

ITEM	ID	OD	h
PU-P-018	18	22	1.25
PU-P-045	45	51	1.25
PU-P-075	75	85	1.9
PU-P-090	90	100	1.9
PU-P-100	100	110	1.9
PU-P-145	145	155	1.9
PU-P-145	145	160	2.1
PU-P-215	215	230	2.1
PU-P-235	235	250	2.1
PU-P-155	155	170	2.5
PU-P-170	170	185	2.75
PU-G-035	35	40	1.25
PU-G-040	40	45	1.25
PU-G-045	45	50	1.25
80-230	63.7	69.3	1.2
80-232	70	76	1.25
80-234	76.35	82.35	1.25
80-236	82.7	88.7	1.25
80-240	95.4	101.4	1.1
80-244	108.1	114.1	1.25
80-246	114.45	120.45	1.25
80-262	178.26	184.26	1.25
80-264	190.96	196.96	1.25
80-266	203.66	209.66	1.25
80-266	203.66	209.66	1.25
80-268	216.3	222.3	1.25

4F BACKUP RING

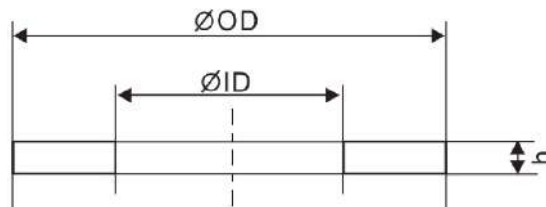

APPLICATION		
MATERIAL	HY	POK
TEMP.	-40°C~100°C	-30°C~120°C

ITEM	ID	OD	h	ITEM	ID	OD	h
4F-12	12	14	1	4F-60	60	75	2
4F-15	15	17	1	4F-60	60	80	2
4F-25	25	33	1	4F-60.4	60.4	54	2
4F-36	36	46	1	4F-61	61	71	2
4F-120	120	130	1	4F-63	63	78	2
* 4F-4	4	12	2	4F-65	65	57	2
4F-10	10	20	2	4F-65	65	75	2
* 4F-14	14	22	2	4F-65	65	80	2
* 4F-16	16	24	2	4F-70	70	80	2
4F-18	18	26	2	4F-70	70	85	2
4F-22	22	30	2	4F-70	70	90	2
4F-22.4	22.4	30	2	4F-71	71	80	2
4F-25	25	35	2	4F-75	75	90	2
4F-28	28	35.5	2	4F-75	75	95	2
4F-28	28	36	2	4F-80	80	95	2
4F-28	28	40	2	4F-80	80	100	2
4F-30	30	40	2	4F-85	85	100	2
4F-30	30	43	2	4F-85	85	105	2
* 4F-30	30	45	2	4F-90	90	105	2
* 4F-32	32	42	2	4F-90	90	110	2
* 4F-32	32	48	2	4F-90.4	90.4	100	2
4F-35	35	45	2	4F-95	95	110	2
4F-35	35	50	2	4F-95	95	115	2
4F-36	36	44	2	4F-100	100	115	2
4F-36	36	46	2	4F-100	100	120	2
* 4F-38	38	41	2	4F-105	105	120	2
4F-38	38	48	2	* 4F-106	106	111	2
4F-40	40	48	2	4F-106	106	120	2
4F-40	40	50	2	4F-110	110	125	2
4F-40	40	53	2	4F-110	110	130	2
4F-40	40	55	2	4F-112	112	125	2
4F-40	40	60	2	4F-115	115	130	2
4F-42	42	55	2	4F-115	115	135	2
4F-45	45	55	2	4F-120	120	135	2
4F-45	45	60	2	4F-120	120	140	2
4F-50	50	60	2	4F-123.7	123.7	132	2
4F-50	50	63	2	4F-125	125	140	2
4F-50	50	65	2	4F-125	125	145	2
4F-50	50	70	2	4F-125	125	150	2
4F-55	55	75	2	4F-130	130	145	2
4F-60	60	70	2	4F-135	135	150	2
4F-60	60	71	2	4F-136	136	150	2

4F BACKUP RING

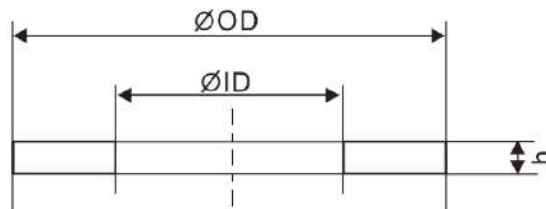

APPLICATION		
MATERIAL	HY	POK
TEMP.	-40°C~100°C	-30°C~120°C

ITEM	ID	OD	h	ITEM	ID	OD	h
4F-140	140	155	2	4F-60	60	70	3
4F-140	140	160	2	4F-60	60	71	3
4F-145	145	160	2	4F-60	60	73	3
4F-145	145	170	2	4F-60	60	75	3
4F-155	155	170	2	4F-65	65	78	3
4F-155	155	180	2	4F-65	65	85	3
4F-160	160	175	2	4F-70	70	80	3
4F-165	165	180	2	4F-70	70	83	3
4F-170	170	190	2	4F-70	70	85	3
4F-175	175	190	2	4F-70	70	90	3
4F-180	180	200	2	4F-75	75	85	3
4F-180	180	205	2	4F-75	75	88	3
4F-190	190	210	2	* 4F-75	75	90	3
4F-190	190	215	2	4F-75	75	95	3
4F-195	195	220	2	4F-80	80	90	3
4F-200	200	220	2	4F-80	80	93	3
4F-250	250	280	2	4F-80	80	95	3
4F-255.5	255.5	265	2	4F-80	80	100	3
4F-10	10	14	3	4F-85	85	100	3
4F-30	30	43	3	4F-90	90	100	3
4F-32	32	48	3	4F-90	90	105	3
4F-35	35	45	3	4F-90	90	110	3
4F-35	35	50	3	* 4F-90.4	90.4	100	3
4F-35.5	35.5	45	3	4F-95	95	110	3
4F-38	38	48	3	4F-100	100	115	3
4F-40	40	50	3	4F-100	100	120	3
4F-40	40	55	3	4F-106	106	120	3
4F-40	40	60	3	4F-110	110	125	3
4F-45	45	55	3	4F-112	112	125	3
4F-45	45	61	3	4F-115	115	135	3
4F-50	50	60	3	4F-120	120	135	3
4F-50	50	63	3	4F-125	125	140	3
4F-50	50	65	3	4F-125	125	145	3
4F-50	50	70	3	4F-125	125	150	3
4F-53	53	63	3	4F-130	130	150	3
4F-55	55	68	3	4F-136	136	150	3
4F-55	55	70	3	4F-140	140	160	3
4F-55	55	75	3	4F-140	140	165	3
4F-56	56	66	3	4F-145	145	165	3
4F-56	56	71	3	4F-150	150	170	3

4F BACKUP RING

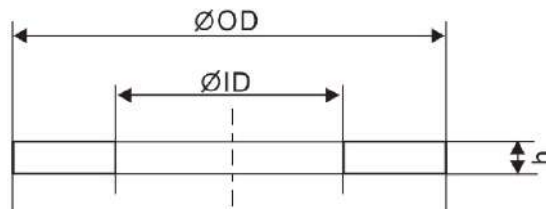

APPLICATION		
MATERIAL	HY	POK
TEMP.	-40°C~100°C	-30°C~120°C

ITEM	ID	OD	h	ITEM	ID	OD	h
4F-155	155	170	3	4F-150	150	170	4
4F-160	160	175	3	4F-160	160	175	4
4F-160	160	180	3	4F-160	160	180	4
4F-160	160	185	3	4F-180	180	205	4
4F-165	165	180	3	4F-190	190	210	4
4F-170	170	190	3	4F-215	215	235	4
4F-175	175	190	3	4F-225	225	250	4
4F-180	180	200	3	4F-235	235	260	4
4F-180	180	205	3	4F-240	240	260	4
4F-185	185	205	3	4F-270	270	300	4
4F-190	190	210	3	4F-300	300	330	4
4F-195	195	215	3	4F-300	300	332	4
4F-200	200	225	3	4F-310	310	340	4
4F-200	200	230	3	4F-320	320	350	4
4F-204	204	224	3	4F-330	330	360	4
4F-230	230	250	3	4F-335	335	355	4
4F-230	230	255	3	4F-340	340	370	4
4F-235	235	260	3	4F-360	360	390	4
4F-300	300	320	3	4F-365	365	395	4
4F-300	300	330	3	4F-370	370	400	4
4F-320	320	350	3	4F-380	380	410	4
4F-330	330	355	3	4F-390	390	420	4
4F-330	330	360	3	4F-430	430	470	4
4F-340	340	370	3	4F-440	440	480	4
4F-350	350	380	3	4F-450	450	480	4
4F-360	360	390	3	4F-450	450	482	4
4F-370	370	400	3	4F-475	475	507	4
4F-375	375	407	3	4F-480	480	505	4
4F-380	380	400	3	4F-500	500	540	4
4F-415	415	450	3	4F-560	560	600	4
4F-430	430	470	3	4F-570	570	600	4
4F-460	460	500	3	4F-420	420	455	5
4F-475	475	507	3	4F-430	430	470	5
4F-500	500	532	3	4F-450	450	482	5
4F-570	570	600	3	4F-457.2	457.2	488.95	5
4F-140	140	160	4	4F-530	530	570	5
4F-145	145	165	4	4F-560	560	600	5

O-RING KIT—AS-568 SERIES



ITEM	SPECIFICATION
KIT-AS568-NBR70	RED CASE, 378PCS
KIT-AS568-NBR90	RED CASE, 378PCS

INCLUDING 30 SIZES, TOTAL 378PCS, DETAILS AS BELOW:

ITEM	ID	OD	C/S	Q'TY
AS-006	2.90	6.46	1.78	18
AS-007	3.68	7.25	1.78	18
AS-008	4.47	8.03	1.78	20
AS-009	5.28	8.84	1.78	20
AS-010	6.07	9.63	1.78	20
AS-011	7.65	11.21	1.78	20
AS-012	9.25	12.81	1.78	20
AS-110	9.19	14.44	2.62	13
AS-111	10.77	16.01	2.62	13
AS-112	12.37	17.61	2.62	13
AS-113	13.95	19.19	2.62	13
AS-114	15.54	20.78	2.62	13
AS-115	17.12	22.36	2.62	13
AS-116	18.72	23.96	2.62	13
AS-210	18.64	25.70	3.53	10
AS-211	20.22	27.28	3.53	10
AS-212	21.82	28.88	3.53	10
AS-213	23.40	30.46	3.53	10
AS-214	24.99	32.06	3.53	10
AS-215	26.57	33.63	3.53	10
AS-216	28.17	35.23	3.53	10
AS-217	29.75	36.81	3.53	10
AS-218	31.34	38.40	3.53	10
AS-219	32.92	39.98	3.53	10
AS-220	34.52	41.58	3.53	10
AS-221	36.10	43.16	3.53	10
AS-222	37.69	44.76	3.53	10
AS-325	37.46	48.15	5.33	7
AS-326	40.64	51.33	5.33	7
AS-327	43.82	54.50	5.33	7

O-RING KIT—AS-568 SERIES



ITEM	SPECIFICATION
KIT-AS568-FKM75	BLUE CASE, 378PCS

INCLUDING 30 SIZES, TOTAL 378PCS, DETAILS AS BELOW:

ITEM	ID	OD	C/S	Q'TY
AS-006	2.90	6.46	1.78	18
AS-007	3.68	7.25	1.78	18
AS-008	4.47	8.03	1.78	20
AS-009	5.28	8.84	1.78	20
AS-010	6.07	9.63	1.78	20
AS-011	7.65	11.21	1.78	20
AS-012	9.25	12.81	1.78	20
AS-110	9.19	14.44	2.62	13
AS-111	10.77	16.01	2.62	13
AS-112	12.37	17.61	2.62	13
AS-113	13.95	19.19	2.62	13
AS-114	15.54	20.78	2.62	13
AS-115	17.12	22.36	2.62	13
AS-116	18.72	23.96	2.62	13
AS-210	18.64	25.70	3.53	10
AS-211	20.22	27.28	3.53	10
AS-212	21.82	28.88	3.53	10
AS-213	23.40	30.46	3.53	10
AS-214	24.99	32.06	3.53	10
AS-215	26.57	33.63	3.53	10
AS-216	28.17	35.23	3.53	10
AS-217	29.75	36.81	3.53	10
AS-218	31.34	38.40	3.53	10
AS-219	32.92	39.98	3.53	10
AS-220	34.52	41.58	3.53	10
AS-221	36.10	43.16	3.53	10
AS-222	37.69	44.76	3.53	10
AS-325	37.46	48.15	5.33	7
AS-326	40.64	51.33	5.33	7
AS-327	43.82	54.50	5.33	7

O-RING KIT—JIS P&G SERIES



ITEM	SPECIFICATION
KIT-PG-NBR70	YELLOW COLOR, 394PCS
KIT-PG-NBR90	YELLOW COLOR, 388PCS

INCLUDING 30 SIZES, TOTAL 394(388)PCS, DETAILS AS BELOW :

ITEM	ID	OD	C/S	NBR70	NBR90
				Q'TY	Q'TY
P-003	2.80	6.60	1.90	20	18
P-004	3.80	7.60	1.90	20	18
P-005	4.80	8.60	1.90	18	18
P-006	5.80	9.60	1.90	18	18
P-007	6.80	10.60	1.90	18	17
P-008	7.80	11.60	1.90	18	18
P-009	8.80	12.60	1.90	18	18
P-010A	9.80	14.60	2.40	14	14
P-011	10.80	15.60	2.40	14	14
P-012	11.80	16.60	2.40	14	14
P-014	13.80	18.60	2.40	14	14
P-016	15.80	20.60	2.40	14	14
P-018	17.80	22.60	2.40	14	14
P-020	19.80	24.60	2.40	13	13
	20.00	26.00	3.00	11	11
	22.00	28.00	3.00	11	11
G-025	24.40	30.60	3.10	11	11
G-030	29.40	35.60	3.10	11	11
G-035	34.40	40.60	3.10	11	11
G-040	39.40	45.60	3.10	11	11
G-045	44.40	50.60	3.10	11	11
P-022.4	22.10	29.10	3.50	10	10
P-025	24.70	31.70	3.50	10	10
P-026	25.70	32.70	3.50	10	9
P-030	29.70	36.70	3.50	10	10
P-032	31.70	38.70	3.50	10	10
P-034	33.70	40.70	3.50	10	10
P-036	35.70	42.70	3.50	10	10
P-040	39.70	46.70	3.50	10	10
P-048	47.70	54.70	3.50	10	10

O-RING KIT—METRIC SERIES



ITEM	SPECIFICATION
KIT-METRIC-NBR70	BLUE CASE, 382PCS
KIT-METRIC-NBR90	BLUE CASE, 382PCS

INCLUDING 30 SIZES, TOTAL 382PCS, DETAILS AS BELOW :

ID	OD	C/S	Q'TY
3.00	7.00	2.00	18
4.00	8.00	2.00	18
5.00	9.00	2.00	17
6.00	10.00	2.00	17
7.00	11.00	2.00	17
8.00	12.00	2.00	17
10.00	14.00	2.00	17
10.00	15.00	2.50	13
11.00	16.00	2.50	13
12.00	17.00	2.50	13
14.00	19.00	2.50	13
16.00	21.00	2.50	13
17.00	22.00	2.50	13
19.00	24.00	2.50	13
19.00	25.00	3.00	11
20.00	26.00	3.00	11
22.00	28.00	3.00	11
24.00	30.00	3.00	11
25.00	31.00	3.00	11
27.00	33.00	3.00	11
28.00	34.00	3.00	11
30.00	36.00	3.00	11
32.00	38.00	3.00	11
33.00	39.00	3.00	11
35.00	41.00	3.00	11
36.00	42.00	3.00	11
38.00	44.00	3.00	11
38.00	46.00	4.00	9
42.00	50.00	4.00	9
45.00	53.00	4.00	9

O-RING KIT—KOMATSU



ITEM	SPECIFICATION
KIT-KOMATSU-NBR 90	RED COLOR , 394PCS

INCLUDING 30 SIZES, TOTAL 394 PCS, DETAILS AS BELOW :

NO	SIZES	Q'TY	NO	SIZES	Q'TY
006	07000-11003	18	211	07000-12022	15
007	07000-11004	18	212	07000-13022	10
008	07000-11005	18	213	07000-12025	11
009	07000-11006	18	214	07000-13025	10
010	07000-11007	18	215	07000-13026	10
011	07000-11008	18	216	07000-12030	11
012	07000-11009	18	217	07000-13030	10
110	07000-12010	14	218	07000-13032	10
111	07000-12011	14	219	07000-13034	10
112	07000-12012	14	220	07000-12035	11
113	07000-12014	14	221	07000-13036	10
114	07000-12016	14	222	07000-12040	11
115	07000-12018	14	325	07000-13040	10
116	07000-12020	14	326	07000-12045	11
210	07000-13020	10	327	07000-13048	10

O-RING KIT—HITACHI



ITEM	SPECIFICATION
KIT-HITACHI-NBR90	350 PCS

INCLUDING 36 SIZES, TOTAL 356 PCS, DETAILS AS BELOW :

NO	PART NO.	QTY
1	4506404	12
2	4506405 4038403 A813005 0619307	13
3	4506406 4500581 0669106	13
4	4506407 0232126 4034659 4035038 4045632 4505092 4350187 4511428	13
5	4506408 0232127	13
6	4506409 R28782 4212036	13
7	4506320 A813010 0117633 4501265	13
8	4317636 0126307 4500578 971823	10
9	957366 0212115 0249307	10
10	4506412 0130526 0166806 4014875 4007530	10
11	4509180 0134414 4039948 4081845 4501764 4350206	10
12	4506415 0225314 4029572 4035821 4226444 4038402	10
13	4506416 0125433 0195306 4003134 4018070 0669501	10
14	4506418 0126308 0211506	10
15	4506420 0117670 0130525 0134450 4511267	10
16	4509181 0134413 0178609 4004558 4006808 955655	10
17	4028265 0130524 0139210 4036815 4226443	7
18	4506424 0134434 0217122 4048315 965702	8
19	966689 0166704	8
20	A811025 0134415 0134422 0159814 4003062 0391721	9
21	4509182 0134460 0153109 4226446	8
22	4506428 0159712 0217128 0234514	8
23	4506430 0173618 0199005 4048843 4104498	8
24	A811030 0134607 0210734 0232125 4036814 4200487	9
25	985098 0225309	8
26	984614 4038867 4070049	8
27	4018880	8
28	A811035 0125801 0130605 4511395 4514164	9
29	970860 4006684	8
30	A811040 4511394 0272503	8
31	985096 4045633	8
32	A811045 0249308 4060895	8
33	4138938 0159307 0159219 0135201	10
34	4187308 4009553	10
35	4187328	10
36	4187329	10

O-RING KIT—JASO SERIES



ITEM	SPECIFICATION
KIT-JASO-NBR90	BLUE CASE, 600 PCS

INCLUDING 20 SIZES, TOTAL 600 PCS, DETAILS AS BELOW :

ITEM	ID	OD	C/S	Q'TY
1011	11.0	14.8	1.9	30
1012	12.3	16.1	1.9	30
1013	13.0	16.8	1.9	30
1014	13.8	17.6	1.9	30
1015	14.8	18.6	1.9	30
1016	15.8	19.6	1.9	30
1017	16.8	20.6	1.9	30
1018	17.8	21.6	1.9	30
1019	18.8	22.6	1.9	30
1020	19.8	23.6	1.9	30
1021	21.0	24.8	1.9	30
1022	22.1	25.9	1.9	30
1023	23.3	27.1	1.9	30
1025	24.7	28.5	1.9	30
1026	26.2	30.0	1.9	30
1028	27.7	31.5	1.9	30
1030	29.7	33.5	1.9	30
1031	31.2	35.0	1.9	30
1033	33.2	37.0	1.9	30
1035	35.2	39.0	1.9	30

BACKUP RING KIT— 4F-JIS P&G SERIES



INCLUDING 29 SIZES, TOTAL 384PCS:

ITEM	ID	OD	C/S	Q'TY	ITEM	ID	OD	C/S	Q'TY
P-003	3	6	1.25	18	P-022	22	26	1.25	15
P-004	4	7	1.25	18	P-022A	22	28	1.25	10
P-005	5	8	1.25	18	P-025	25	31	1.25	10
P-006	6	9	1.25	18	P-026	26	32	1.25	10
P-007	7	10	1.25	18	P-030	30	36	1.25	10
P-008	8	11	1.25	18	P-032	32	38	1.25	10
P-009	9	12	1.25	18	P-034	34	40	1.25	10
P-010A	10	14	1.25	14	P-036	36	42	1.25	10
P-011	11	15	1.25	14	P-040	40	46	1.25	10
P-012	12	16	1.25	14	P-048	48	54	1.25	10
P-014	14	18	1.25	14	G-025	25	30	1.25	11
P-016	16	20	1.25	14	G-030	30	35	1.25	11
P-018	18	22	1.25	14	G-035	35	40	1.25	11
P-020	20	24	1.25	14	G-040	40	45	1.25	11
					G-045	45	50	1.25	11

4F-AS 568 SERIES



INCLUDING 36 SIZES, TOTAL 325PCS:

ITEM	ID	OD	C/S	Q'TY	ITEM	ID	OD	C/S	Q'TY
AS-005	3.15	5.85	1.25	15	AS-114	16.26	20.62	1.25	10
AS-006	3.56	6.26	1.25	15	AS-115	17.83	22.19	1.25	10
AS-007	4.34	7.04	1.25	15	AS-116	19.43	23.79	1.25	10
AS-008	5.13	7.83	1.25	15	AS-117	21.1	25.46	1.25	5
AS-009	5.94	8.64	1.25	15	AS-118	22.7	27.06	1.25	5
AS-010	6.73	9.43	1.25	15	AS-119	24.3	28.66	1.25	5
AS-011	8.3	11	1.25	15	AS-120	25.9	30.26	1.25	5
AS-012	9.9	12.6	1.25	15	AS-121	27.48	31.84	1.25	5
AS-013	11.56	14.26	1.25	10	AS-210	19.46	25.46	1.25	5
AS-014	13.16	15.86	1.25	10	AS-211	21.03	27.03	1.25	5
AS-015	14.73	17.43	1.25	10	AS-212	22.63	28.63	1.25	5
AS-016	16.33	19.03	1.25	10	AS-213	24.21	30.21	1.25	5
AS-017	17.91	20.61	1.25	10	AS-214	25.81	31.81	1.25	5
AS-018	19.51	22.21	1.25	10	AS-215	27.38	33.38	1.25	5
AS-110	9.91	14.27	1.25	10	AS-216	29	35	1.25	5
AS-111	11.48	15.84	1.25	10	AS-217	30.56	36.56	1.25	5
AS-112	13.08	17.44	1.25	10	AS-218	32.1	38.1	1.25	5
AS-113	14.66	19.02	1.25	10	AS-219	34.138	40.138	1.25	5

O-RING KIT—SAE900 BOSS



ITEM	SPECIFICATION
KIT-N9008	212 PCS

INCLUDING 20 SIZES, TOTAL 600 PCS, DETAILS AS BELOW :

ITEM	Tube OD	ID	OD	C/S	Q'TY
AS-901	3/32	4.7	7.54	1.4	10
AS-902	1/8	6.1	9.3	1.6	10
AS-903	3/16	7.7	10.9	1.6	10
AS-904	1/4	8.9	12.6	1.8	10
AS-905	5/16	10.5	14.2	1.8	12
AS-906	3/8	11.9	15.9	2.0	12
AS-907	7/16	13.5	17.6	2.1	12
AS-908	1/2	16.4	20.8	2.2	12
AS-909	9/16	17.9	22.9	2.5	12
AS-910	5/8	19.2	24.1	2.5	12
AS-911	11/16	21.9	27.8	3.0	10
AS-912	3/4	23.5	29.4	3.0	10
AS-913	13/16	25.0	30.9	3.0	10
AS-914	7/8	26.6	32.5	3.0	10
AS-916	1	29.7	35.6	3.0	10
AS-918	1-1/8	34.4	40.3	3.0	10
AS-920	1-1/4	37.5	43.5	3.0	10
AS-924	1-1/2	43.7	49.7	3.0	10
AS-928	1-3/4	53.1	59.1	3.0	10
AS-932	2	59.4	65.4	3.0	10

O-RING KIT



PICTURE	DESCRIPTION	MATERIAL
	<p>JIS PG SERIES (30 sizes, 394/388pcs)</p>	<p>NBR</p>
	<p>JASO SERIES (20 sizes, 600pcs)</p>	<p>NBR</p>
	<p>AS 568 SERIES (30 sizes, 378pcs)</p>	<p>NBR</p>
	<p>AS568 SERIES (30 sizes, 378pcs)</p>	<p>FKM</p>
	<p>METRIC SERIES (30 sizes, 382pcs)</p>	<p>NBR</p>
	<p>HITACHI (36 sizes, 350pcs)</p>	<p>NBR</p>
	<p>HOSE FITTING O-RING KIT (11 sizes, 220pcs)</p>	<p>NBR 90</p>

O-RING KIT



PICTURE	DESCRIPTION	MATERIAL
	<p>KIT-REX-SL FOR SL/SV SERIES 10/20/30</p>	<p>NBR 90</p>
	<p>ED SEALS ACCORDING TO DIN 3869 (15 size , 300pcs)</p>	<p>NBR</p>
	<p>WD SEALS FOR THREADED CONNECTORS (10size, 200pcs)</p>	<p>FKM</p>
	<p>270-1537(4C4788) Metric Straight Thread O-Ring kit (10size , 125pcs)</p>	<p>NBR</p>
	<p>CAT. 4C-8253 (32 sizes, 149 pcs)</p>	<p>SILCONE</p>
	<p>CAT. 4C-4782 (32 sizes, 570 pcs)</p>	<p>NBR</p>
	<p>CAT. D-RING 4C-4784 (9 sizes, 80 pcs)</p>	<p>NBR</p>



O-RING KIT





PICTURE	DESCRIPTION	MATERIAL
	<p>CAT. 4C-5859 (8 sizes, 150 pcs)</p>	<p>NBR+PTFE</p>
	<p>CAT. 270-1545 (6 sizes, 60 pcs)</p>	<p>NBR</p>
	<p>KOMATSU (30 sizes, 394pcs)</p>	<p>NBR</p>
	<p>KOMATSU KOM-30-KU-90 (30 sizes, 239 pcs) (21T series+07000-1 series)</p>	<p>PU / NBR</p>
	<p>HITACHI E12979373 O-RING KIT (46 sizes, 484pcs)</p>	<p>FKM</p>
	<p>VOLVO 14511214 (24 sizes, 424 pcs)</p>	<p>NBR</p>
	<p>SANY KIT-N9007R1 (25 sizes, 250 pcs)</p>	<p>NBR</p>

O-RING KIT



PICTURE	DESCRIPTION	MATERIAL
	<p>John Deere AT85197 (8 sizes, 80 pcs)</p>	<p>NBR</p>
	<p>O RING PICK SET</p>	<p>PLASTIC</p>

BACKUP-RING KIT

PICTURE	DESCRIPTION	MATERIAL
	<p>JIS PG SERIES (29 sizes, 384 pcs)</p>	<p>PTFE</p>
	<p>AS 568 SERIES (36 sizes, 325 pcs)</p>	<p>PTFE</p>

CONTROL VALVE O RING KITS



MODEL	PART NO.
-------	----------

FOR HITACHI:

ZAX200	4S00689
EX200-5	4S00690
EX200-2 / EX200-3	4S00691
ZAX200-3	4S00727
ZAX330	4S00735
ZAX330-3	4S00736
ZAX230	4S00762
ZAX240-3	4S00763

FOR KOMATSU:

- PC60-5/6
- PC60-7
- PC100-5/6
- PC120-3/5
- PC120-6 -1
- PC120-6 -2
- PC200-5
- PC200-7/8
- PC300-5/6

FOR CAT:

- 330D/336D
- 330C
- 329D
- 325D
- 320D/323D
- 320C



PETSEALS INDUSTRIES LTD.

ADD:No.9, Ln.229, Sec.1, Zhongshan Rd.,
Wuri Dist., Taichung City 414, Taiwan

TEL:886-4-23367239 FAX:886-4-23366057

E-mail: petseals@petseals.com